

**Only**

**FONTAINE®**

**Gives You the TechLock® System Advantage**

# Rebuild

**ASSEMBLY, DISASSEMBLY  
& TROUBLESHOOTING  
INSTRUCTIONS  
NO-SLACK® II  
6000 & 7000  
SERIES**



**FOR YOUR SAFETY USE  
ONLY GENUINE FONTAINE  
SERVICE PARTS. USING  
PARTS THAT DO NOT MEET  
FONTAINE SPECIFICATIONS  
WILL VOID WARRANTY.**

  
**FONTAINE**  
FIFTH WHEEL®

# NO-SLACK® II DISASSEMBLY

Degrease fifth wheel before installing new parts.

For 6000 & 7000 Series Fifth Wheels (procedures are the same for both series).

Refer to exploded view of assembly on page 7 to identify item numbers and parts.

**1** Remove secondary lock spring and bumper spring. Remove pull handle cotter pin and washer then slide out pull handle.

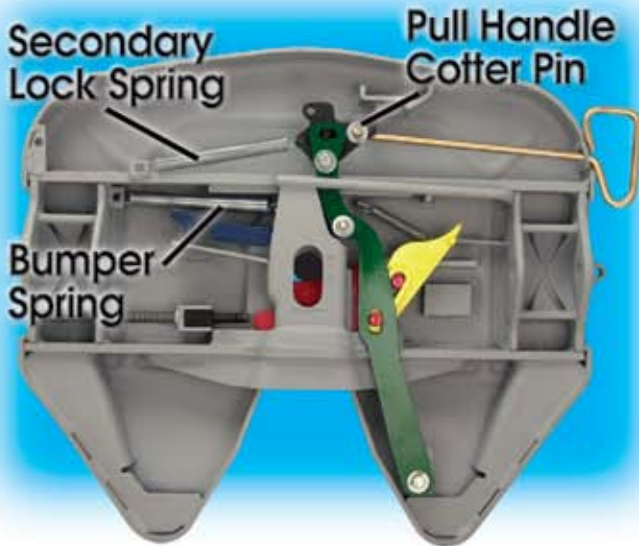

**2** Unbolt and remove secondary lock from operating handle. Discard lock nut and bushing.

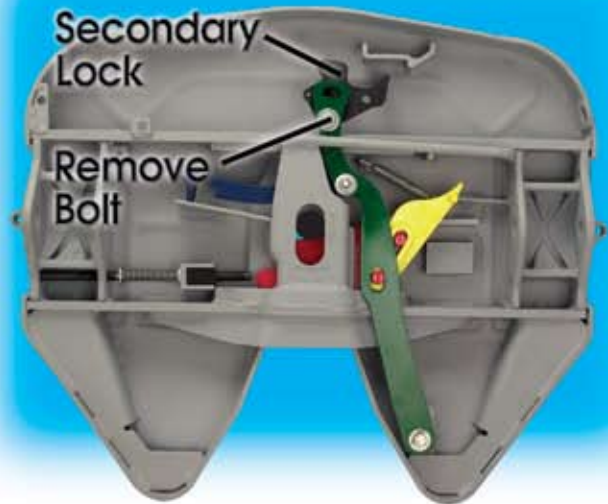

**3** Unbolt and remove bumper from operating handle. Discard lock nut and bushing.

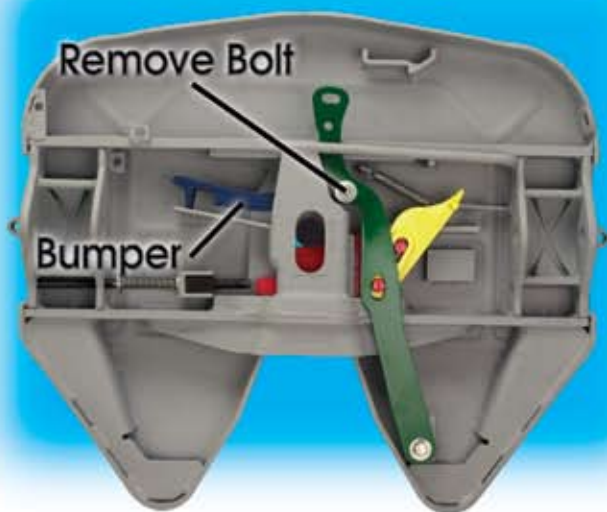

**4** Unbolt operating handle from pivot mount and remove. Discard lock nut.

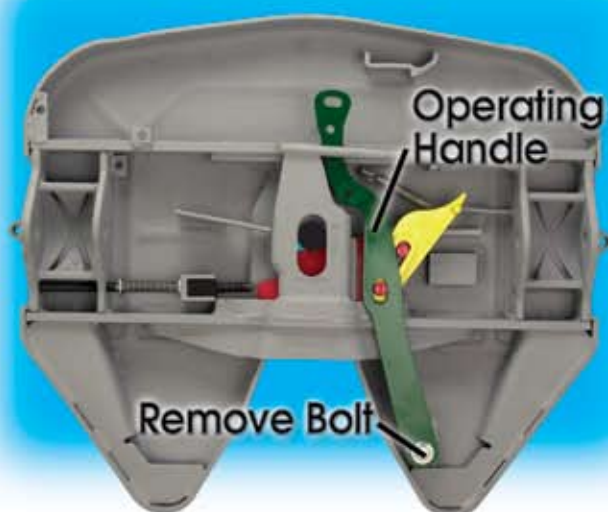

**Caution: Always wear safety glasses and do not stand directly over parts while disassembling or assembling wheel.**

# NO-SLACK® II DISASSEMBLY

**5** Remove timer spring and timer.

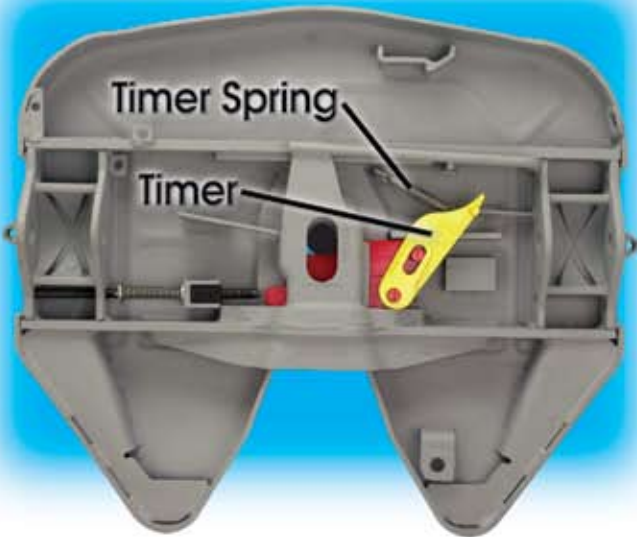

**6** Remove jaw and wedge.

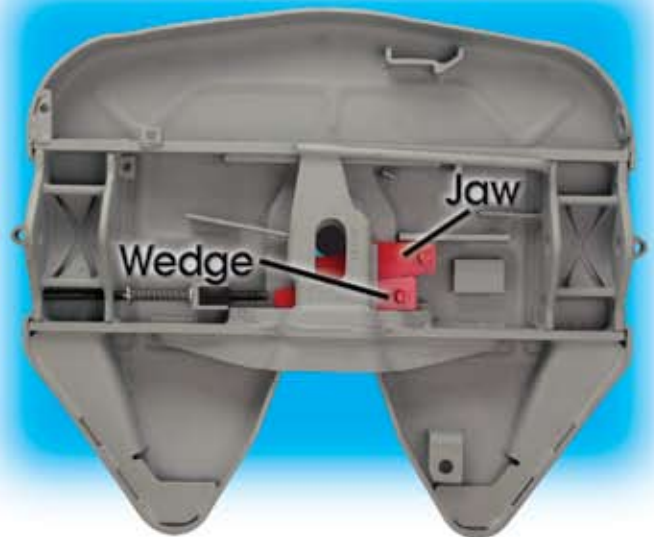

# NO-SLACK® II ASSEMBLY

Adequate lubrication should be used.

Before rebuilding the assembly, check to make sure that there are no cracks in the cross members or other components. Also check bracket pin holes to ensure they are not worn oversize (pins should fit snugly). Under no circumstances should a fifth wheel be repaired or used if any component (cross member, saddle bearing, etc.) is cracked.

**1** Always assemble parts around a 2" kingpin or a 2" diameter shaft. Insert jaw first and then the wedge below it. Grease the jaw and wedge on top and bottom. See note below for more information.



**2** Insert timer and timer spring.

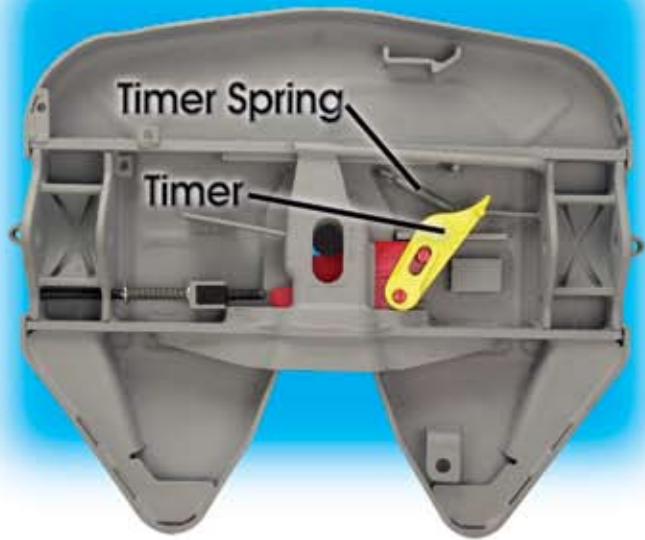

**3** Insert operating handle and bolt to pivot mount. Use existing bolt, washer, hairpin cotter and bushing (inspect for wear before using and replace if necessary). Use the new lock nut that is supplied in the repair kit. Note orientation of bolt - see drawing on page 7 of LT03 pdf file.

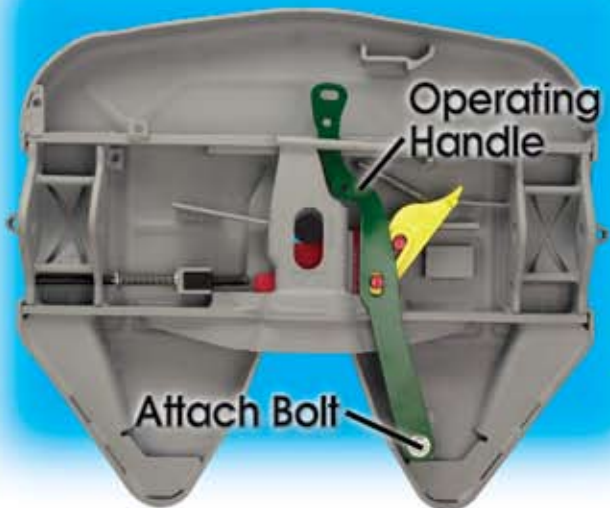

**4** Install bumper and bolt to operating handle. Use existing bolt and washers (inspect for wear before using and replace if necessary). Use new lock nut and bushing that is supplied in the repair kit. Note orientation of bolt - see drawing on page 7 of LT03 pdf file. After installing the bumper check to make sure that it can pivot freely.

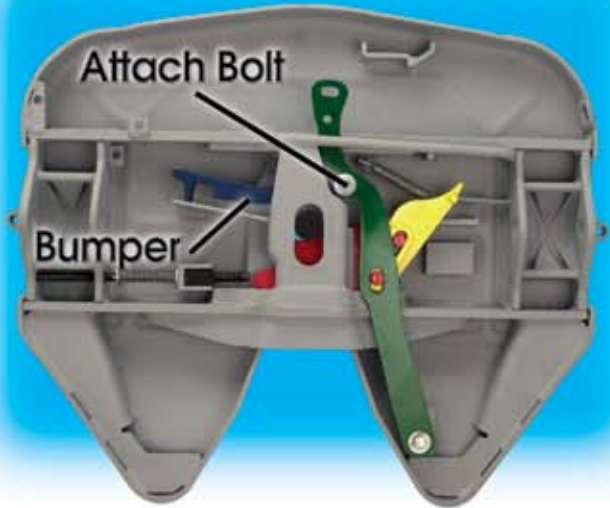

Note: Fontaine suggests the use of a Moly based lubricant such as Mobil grease Moly 50 or equivalent when applying lubricant to the locking jaw and wedge. Lightly oil other moving parts in the fifth wheel.

# NO-SLACK® II ASSEMBLY

**5** Insert secondary lock and bolt to operating handle. Use existing bolt and washers (inspect for wear before using and replace if necessary). Use new lock nut and bushing that is supplied in the repair kit. Note orientation of bolt – see drawing on LT03 pdf file.

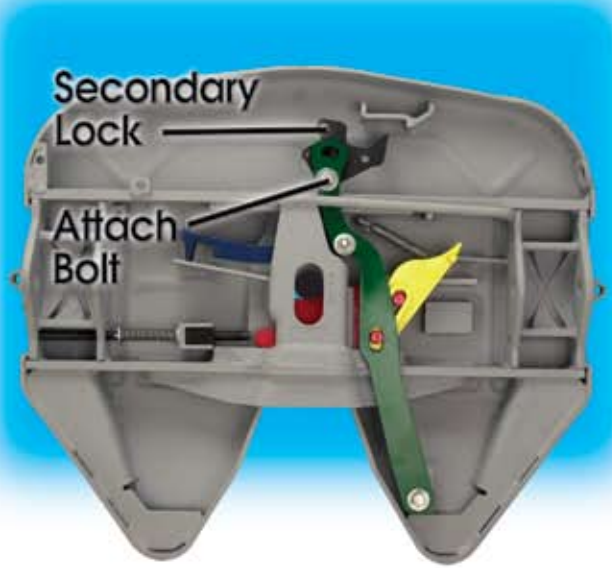

## Conversion of Manual to Air Actuated Release



Your 6000 or 7000 Series fifth wheel can easily be converted to an air actuated release model. Order Part No. "KIT-AA-6000\*" and install per Technical Bulletin TB-004 included.

\*Specify left side (driver's side) or right side (curb side) release by adding an "L" or "R" after Part #.

**6** Install pull handle. Use existing washer and cotter pin (inspect for wear before using and replace if necessary). Attach new secondary lock and bumper spring that is supplied in the repair kit. Now open and close the wheel to ensure that it works properly. Fifth wheel must be properly lubricated before opening and closing the wheel. See note on page 4 LT003 pdf file.

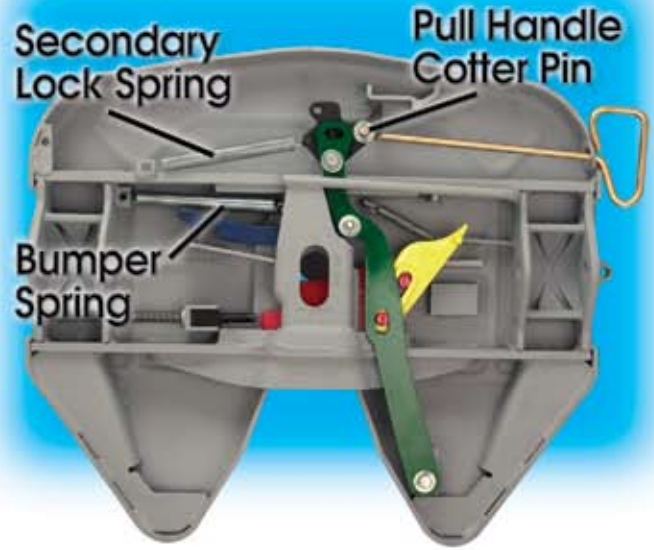

## Wedge Stop Rod Adjustment



Close the fifth wheel several times with a standard 2" kingpin tool. With the lock closed, adjust the wedge stop rod so that the end is 1/4" from the wedge. See troubleshooting section next for additional information.

# NO-SLACK® II REBUILD TROUBLESHOOTING

Problem	Possible Cause	Remedy
Difficulty Coupling	<ol style="list-style-type: none"> <li>1. Kingpin too high to trip latch.</li> <li>2. Damaged trailer plate or kingpin.</li> </ol>	<ol style="list-style-type: none"> <li>1. Lower landing gear</li> <li>2. Check trailer plate for flatness. Check kingpin for squareness with trailer plate.</li> </ol>
Excessive wear on fifth wheel top plate	<ol style="list-style-type: none"> <li>1. Damaged trailer plate.</li> </ol>	<ol style="list-style-type: none"> <li>1. If trailer plate is not flat – replace it.</li> </ol>
Difficulty uncoupling	<ol style="list-style-type: none"> <li>1. Pressure on locking mechanism caused by truck drifting apart from trailer putting excess pressure on lock</li> <li>2. Oval-shaped kingpin</li> <li>3. Debris build-up in the grease</li> </ol>	<ol style="list-style-type: none"> <li>1. Back up tractor and set brakes. Strike the wedge stop rod which protrudes through the side of the fifth wheel. This spring loaded rod will release the pressure on the locking mechanism.</li> </ol>
Slack	<ol style="list-style-type: none"> <li>1. Wedge stop rod not adjusted properly.</li> <li>2. Undersized kingpin</li> <li>3. Worn jaw and wedge</li> </ol>	<ol style="list-style-type: none"> <li>1. Open fifth wheel and insert 2" kingpin or shaft with 2" diameter – Trip the lock and adjust the wedge stop rod so that it is 1/4" from the wedge. See slack adjustment photo page 5.</li> <li>2. Replace kingpin if worn greater than 3 mm (1/8") at 5 m (2") diameter.</li> <li>3. Jaw and wedge could have excessive wear – Replace.</li> </ol>

*Note: All fifth wheel installations must be approved by Fontaine Fifth Wheel.*

# NO-SLACK® II REBUILD DIAGRAM

## SLTPL6000/7000

(Left Side Release Shown)

## SRTPL6000/7000

(Right Side Release)

Note: parts assembly is the same for 6000 and 7000 Series Models

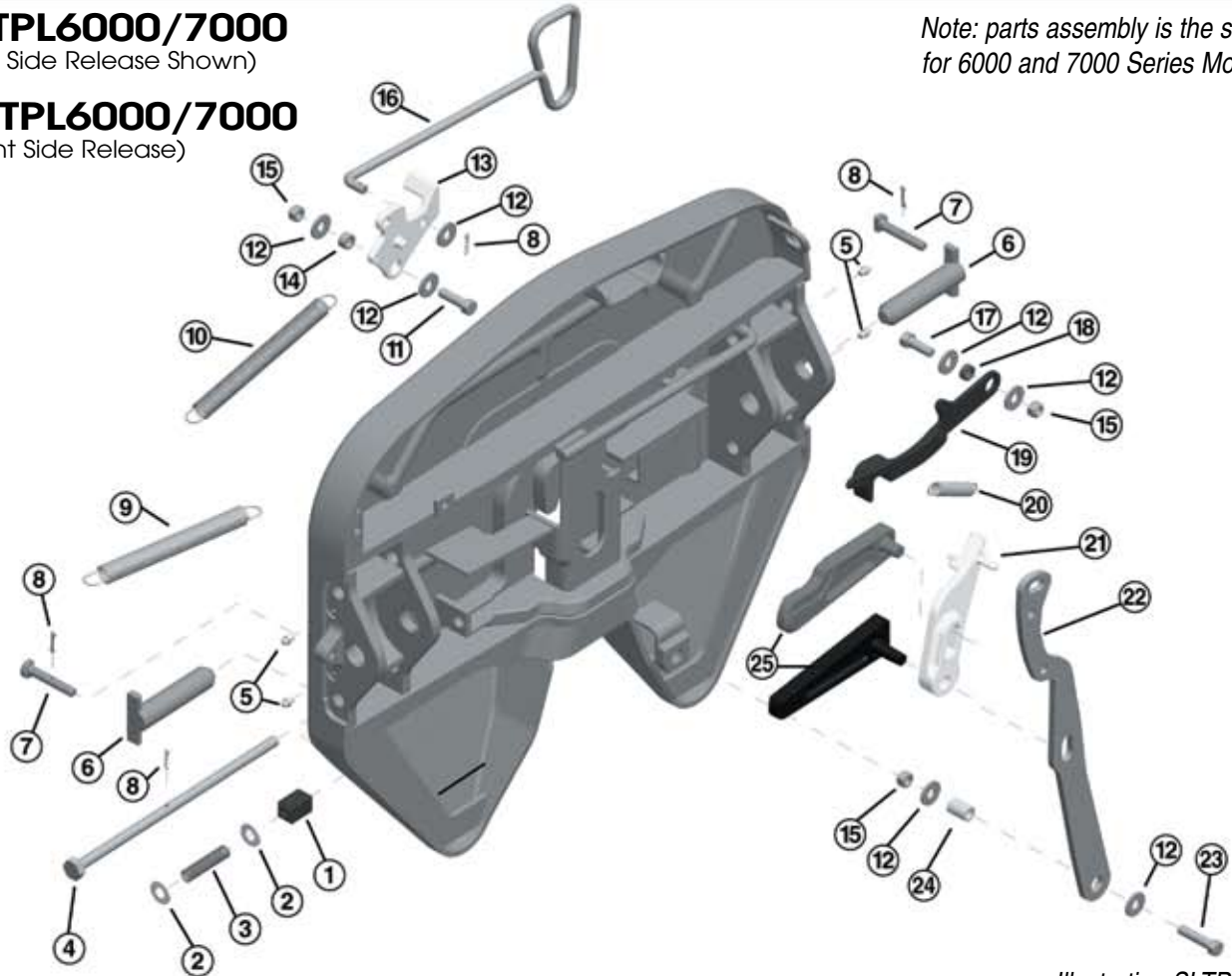

Illustration SLTPL6000

Item No.	Description	Part Number	Quan.
①	Wedge Stop Rod Nut	NUT-319	1
②	Flat Washer, 5/8", Plain	WSH-304-5	2
③	Wedge Stop Rod Spring	SPR-317	1
④	Wedge Stop Rod **	ROD-1108	1
⑤	Grease Fitting	MSC-375	4
⑥	Bracket Pin	PIN-191P	2
⑦	Bracket Retainer Pin	PIN-124P	2
⑧	Cotter Pin, 3/16" x 1"	PIN-165	4
⑨	Bumper Spring	SPR-374	1
⑩	Handle Spring	SPR-338	1
⑪	Hex Head Bolt, 1/2" -13 x 1-1/2 Grade 5	BLT-302-13	1
⑫	Flat Washer, 1/2" I.D. 1-3/8" O.D., Plain	WSH-304-4	7
⑬	Secondary Lock	LAT-6000*	1

Item No.	Description	Part Number	Quan.
⑭	Bushing, 7/16"	BSH-115	1
⑮	Hex Lock Nut, 1/2" - 13, Grade "C"	NUT-303-9	3
⑯	Pull Handle	PUL-6000*	1
⑰	Hex Head Bolt, 1/2" -13 x 1-3/4", BLT-302-14 Grade 5		1
⑱	Bushing, 5/16"	BSH-629	1
⑲	Bumper	BPR-6000*	1
⑳	Timer Spring	CD-SPR-236	1
㉑	Timer	TMR-6000*	1
㉒	Operating Handle	OPR-6000	1
㉓	Hex Head Bolt, 1/2" - 13 x 2-1/4", BLT-302-67		1
㉔	Grade 5		
㉕	Bushing	BSH-1225	1
㉖	Step Jaw and Wedge Set	WED-6000*	1

\* Specify left side (driver's side) or right side (curb side) release by adding an "L" or "R" after Part # (Example: KIT-RPR-6000L).

\*\*Some custom ordered No-Slack® II Series Top Plate models use a knock out rod with no hex head or threads instead of a wedge stop rod as shown above – see ④

# GENUINE FONTAINE® KITS

"Item Number" is shown in Schematic Illustration of Parts on previous page.

Item No.	Description	Quantity
<b>KIT-AA-6000*</b> (See right)		
Air Actuated Conversion Kit		
9	Bumper Spring	1
15	Hex Lock Nut, 1/2" - 13	1
17	Hex Head Bolt, 1/2" - 13	1
27	Air Cylinder	1
28	Shoulder Bolt	1
29	Flat Washer	1
30	Hex Lock Nut, 3/8" - 16	1
<b>KIT-BPR-6000*</b>		
No-Slack® II Series Bumper Kit		
12	Flat Washer, 1/2" I.D.	2
15	Hex Lock Nut, 1/2" - 13	1
17	Hex Head Bolt, 1/2" - 13	1
18	Bushing	1
19	Bumper	1
9	Bumper Spring	1
<b>KIT-LAT-6000*</b>		
No-Slack® II Series Secondary Lock Kit		
8	Cotter Pin, 3/16" x 1"	1
10	Handle Spring	1
12	Flat Washer, 1/2" I.D.	2
11	Hex Head Bolt, 1/2" - 13	1
13	Secondary Lock	1
14	Bushing, 7/16"	1
15	Hex Lock Nut, 1/2" - 13	1
<b>KIT-OPR-6000</b>		
No-Slack® II Series Operating Handle Kit		
12	Flat Washer, 1/2" I.D.	2
14	Bushing, 7/16"	1
15	Lock Nut, 1/2" - 13	3
18	Bushing, 5/16"	1
24	Bushing	1
22	Operating Handle	1
23	Hex Head Bolt, 1/2" - 13	1
26	Hair Pin Cotter	1

Item No.	Description	Quantity
<b>KIT-PIN-191</b>		
Universal Series Pin and Bushing Kit		
8	Cotter Pin, 3/16" x 1"	2
6	Bracket Pin	2
7	Bracket Retainer Pin	2
Not Pictured	Bracket Bushing (pr.)	1
<b>KIT-PUL-6000*</b>		
No-Slack® II Series Pull Handle Kit		
8	Cotter Pin, 3/16" x 1"	1
12	Flat Washer, 1/2" I.D.	1
16	Pull Handle	1
<b>KIT-ROD-1108</b>		
Wedge Stop Rod Kit		
1	Wedge Stop Rod Nut	1
2	Flat Washer, 5/8"	2
3	Wedge Stop Rod Spring	1
4	Wedge Stop Rod	1
8	Cotter Pin, 3/16" x 1"	1
<b>KIT-RPR-6000*</b>		
No-Slack® II Repair Kit		
9	Bumper Spring	1
10	Handle Spring	1
14	Bushing, 7/16"	1
15	Hex Lock Nut, 1/2" - 13	3
18	Bushing, 5/16"	1
20	Timer Spring	1
25	Step Jaw and Wedge Set	1
<b>KIT-TMR-6000*</b>		
No-Slack® II Series Timer Kit		
15	Hex Lock Nut, 1/2" - 13	1
20	Timer Spring	1
21	Timer	1
26	Hair Pin Cotter	1

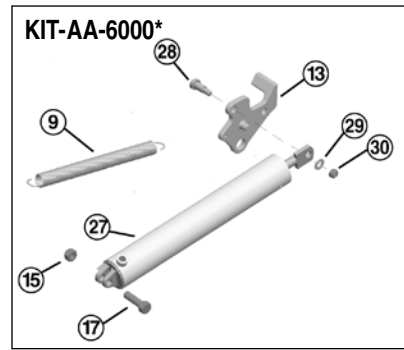

\* Specify left side (driver's side) or right side (curb side) release by adding an "L" or "R" after Part # (Example: KIT-RPR-6000L).

\*\* Some custom ordered No-Slack® II Series Top Plate models use a knock out rod with no hex head or threads instead of a wedge stop rod as shown on page 7 – see (4)



World Wide Headquarters • Fontaine International, Inc. • 5000 Grantswood Road • Suite 200 • Irondale, Alabama 35210  
800-874-9780 • Fax: 205-421-4400

[www.fifthwheel.com](http://www.fifthwheel.com)