



FONTAINE®
FIFTH WHEEL

AFTERMARKET PARTS CATALOG

Your only source for **NO-SLACK®** technology



We make it **EASY**



www.fifthwheel.com

Introduction	Page		Page	Helpful Information	Page
Mobile and Desktop Apps	3	Complete Assemblies	12-13	Important Application Notes ...	23
Part Number Identification	4	Slide Brackets and Rails		Duty Restrictions	24
Measurements	4	NWB	14	Lubrication	25
Serial Number Location	4	LWB	15	Jaw/Wedge Adjustment	26
Top Plate Options	5	LWO	16	Cold Weather Maintenance	27
		ATB	17		
No-Slack® Part Information		AWB	18		
No-Slack® top plate kits	6-8	AWX	19		
No-Slack® H7 kits	8	Stationary Options			
No-Slack® H(X)5092 kits	9	Fixed	20		
3000 part information	10	Blocked Fifth Wheels	21		
CD700 Auto Hauler	11	Pin and Bushing Kits	22		

We make it **EASY**

Fontaine's customer support is unmatched in the aftermarket. *We are your fifth wheel experts; providing cost-cutting training; "How-To" videos; printed materials; digital materials... whatever it takes to help you find the fifth wheel information you need quickly and easily.*

These tools are available on our mobile apps and at fifthwheel.com.



*Convert Holland or Jost
assembly part numbers to Fontaine
No-Slack*



*Download iPhone or Android
version. Links at fifthwheel.com*



*Easy Model# or
Serial# lookup to find
your parts*



Chat at www.fifthwheel.com



*Find the best fifth wheel to
meet your needs*



*EASY order tracking
now available!*



*Learn about the genuine
No-Slack fifth wheels*



*How-To Videos/Training
at www.fifthwheel.com
or use the mobile app!*



*Find your nearest dealer
or repair facility*

www.fifthwheel.com

Get the APP!

Everything you need to know about Fontaine fifth wheels ... at your fingertips.



- Find repair kits
- Track your shipments
- Spec your truck
- Find a location near you
- View literature and Videos
- Troubleshoot problems
- Cross reference

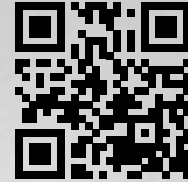

Scan or go to
fifthwheel.com/app

www.fifthwheel.com/app

Introducing H7PMH/X

Versatile mounting plate features Tilt/No-Tilt applications without modifying the top plate

H7PMH & H7PMX (Fifth Wheel Assemblies)

H7 **No-Slack**[®] top plate with
PMH or PMX stationary
adjustable mount

- Heavy/Severe-duty
- 70,000 lbs vertical load
- 200,000 lbs drawbar pull

See page 13 for
complete assemblies

See page 20-21 for
mount and block
assemblies



Part Number Identification

This guide explains the nomenclature for Fontaine Fifth Wheel complete assembly part numbers.

See example part number at right:

SL6NWB675012

Release	Top plate model	Mounting Bracket model	Mounting height	Slide travel
SL = Side left	6 = No-Slack® 6000 Stamped Steel	NWB = Light weight slide bracket	6750 = 6-3/4" Actual height from truck frame to top of fifth wheel.	12 = 12" slide Sliding fifth wheels only.
SR = Side right	7 = No-Slack® 7000 Cast	LWB = Light weight slide bracket	Examples: 7125 = 7-1/8" 7250 = 7-1/4" 8375 = 8-3/8" 9750 = 9-3/4"	Examples: 12 = 12" slide 24 = 24" slide 36 = 36" slide 48 = 48" slide
AA = Air actuated	C = 7000CC Clean Connect Cast	LWO = Light weight slide bracket		
BL = Blocked left (H7 only)	H7 = No-Slack® H7 Cast	ATB = Slide bracket		
AL = Auto-lube left	NT = No-Slack® NT Stamped Steel (Discontinued)	AWB = Slide bracket		
SLE = Electronic lock indicator left (7000 only)	H = No-Slack® 5092 Cast (Discontinued)	AWX = Slide bracket		
		<i>Fixed Mounts</i>		
		BSL = Stationary bracket mount		
		FMA = Stationary bracket mount		
		<i>Plate Mounts</i>		
		PML = Adjustable plate mount		
		APB = Adjustable plate mount		
		PS5 = Stationary plate mount		
		PMH = Stationary plate mount		
		PMX = Stationary plate mount		
		<i>Blocked (Tilt/No-Tilt) Mounts</i>		
		BLH7AWB = Blocked Air slide bracket		
		BLH7PMH = Blocked Stationary short plate mount		
		BLH7PMX = Blocked Stationary short plate mount		

Measurements & Serial Number Location

How do I measure a fifth wheel?

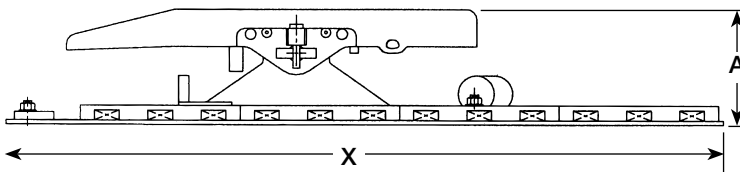

The installed height of all Fontaine models is measured from the top of the truck frame to the top of the fifth wheel. For standard models dimension "A" is a part of the model number. For example, if dimension "A" in this diagram is 7.75 inches, it would appear in the model number as 7750 (Example: SL7AWB775024).

How do I find the serial number

Serial number engraved directly into the right side of fifth wheel skirt. Note: position 5 and 6 of the serial number indicates the year built. Serial number is always 9 digits.



No-Slack® right side view serial number location

No-Slack® Top Plate Options

No-Slack® 6000 series

50,000 pounds vertical load.
150,000 pounds drawbar pull.

The innovative 6000 series stamped steel fifth wheel features the patented self-adjusting No-Slack® locking mechanism with a positive secondary lock that can only be released by pulling the handle. A locking trigger helps minimize high-hitching to reduce tractor, trailer and tire damage. The lock automatically self-adjusts to the trailer kingpin for a smoother ride, lower maintenance costs and longer component life. Rated for standard to moderate duty on-highway use only, including tankers. Gross Combination Weight (GCW) is less than 115,000 lbs. (52,000 kg.). Some restrictions may apply please see the complete application guide on website for details.

Part number

Manual release: **SLTPL6000**
Cab release: **AATPL6000**



No-Slack® 7000 series

55,000 pounds vertical load.
150,000 pounds drawbar pull.

The 7000 series offers all the benefits of our 6000 series, but in a cast design rather than pressed steel. It features the self-adjusting No-Slack® locking mechanism. The 7000 series is rated for standard to heavy duty applications with a Gross Combination Weight (GCW) less than 140,000 lbs. (63,500 kg.). Some restrictions may apply please see the complete application guide on website for details.

Part numbers

Manual release: **SLTPL7000**
Cab release: **AATPL7000**
Lock Sensor model: **SLTPLE7000**



No-Slack® 7000CC series

Clean Connect™
55,000 pounds vertical load.
150,000 pounds drawbar pull.

The 7000CC series Clean-Connect™ offers all the benefits of the 7000 series fifth wheels plus the added benefit of a grease free top plate surface. With Clean-Connect™ technology the fifth wheel no longer requires grease to lubricate between the top plate surface and the trailer coupling plate. This eliminates the labor costs, materials and downtime associated with greasing the top plate surface. The 7000CC series is rated for standard to heavy duty applications with a Gross Combination Weight (GCW) less than 140,000 lbs. (63,500 kg.). Some restrictions may apply please see the complete application guide on website for details.

Part numbers

Manual release: **SLTPL7000CC**
Cab release: **AATPL7000CC**
Lock Sensor w/ Air release: **AATPLE7000CC**



No-Slack® H7 Heavy Duty Series

Rating on AWB mounts	Rating on PMH & PMX
62,500 lbs vertical load	70,000 lbs vertical load
150,000 pounds drawbar	200,000 pounds drawbar pull

The H7 Series offers all the benefits of No-Slack® technology in a steel reinforced cast housing. This rugged workhorse is rated for standard to severe duty applications with a Gross Combination Weight (GCW) that can exceed 140,000 lbs. (63,500 kg.). It's also available as a blocked fifth wheel to accommodate frameless dump applications.

Part number

Manual release: **SLTPLH7**



No-Slack® NT/6000/7000/7000CC

No-Slack® Top Plate Kits

Repair

Repair kit (KIT-RPR-6000L or R)

Item	Description	Qty.
⑥	Bumper spring	1
⑦	Handle spring	1
⑰	Timer spring	1
⑳	Step jaw	1
㉑	Wedge	1
⑩	Bushing, 7/16"	1
⑮	Bushing, 5/16"	1
⑲	Bushing, 1 1/4"	1
⑫	Hex lock nut, 1/2" - 13	3

Spring kit (KIT-SPRING)*

⑥	Bumper spring	1
⑦	Handle spring	1
⑰	Timer spring	1

Wedge-stop rod kit (KIT-ROD-1108)*

①	Wedge-stop rod nut	1
②	Flat washer, 5/8" I.D.	2
③	Wedge-stop rod spring	1
④	Wedge-stop rod	1
⑤	Cotter pin, 3/16" x 1"	1

Secondary lock kit (KIT-LAT-6000L)

⑦	Handle spring	1
⑧	Hex head bolt, 1/2" - 13	1
⑨	Flat washer, 1/2" I.D.	2
⑩	Bushing, 7/16"	1
⑪	Secondary lock	1
⑫	Hex lock nut, 1/2" - 13	1
⑤	Cotter pin, 3/16" x 1"	1

Pull handle kit (KIT-PUL-6000L or R)

⑬	Pull handle	1
⑭	Flat washer, 1/2" I.D.	1
⑤	Cotter pin, 3/16" x 1"	1

Bumper kit (KIT-BPR-6000L)

⑫	Hex lock nut, 1/2" - 13	1
⑭	Flat washer, 1/2" I.D.	2
⑮	Bushing	1
⑧	Hex head bolt, 1/2" - 13	1
⑯	Bumper	1
⑥	Bumper spring	1

Timer kit (KIT-TMR-6000L)

⑰	Timer spring	1
⑱	Timer	1
⑫	Hex lock nut, 1/2" - 13	1
⑤	Hair pin cotter	1

Operating handle kit (KIT-OPR-6000)*

⑩	Bushing, 7/16"	1
⑮	Bushing, 5/16"	1
⑲	Bushing, 1 1/4"	1
⑫	Hex lock nut, 1/2" - 13	3
⑨	Flat washer, 1/2" I.D.	2
⑧	Hex head bolt, 1/2" - 13	1
⑳	Operating handle	1
⑤	Hair pin cotter	1

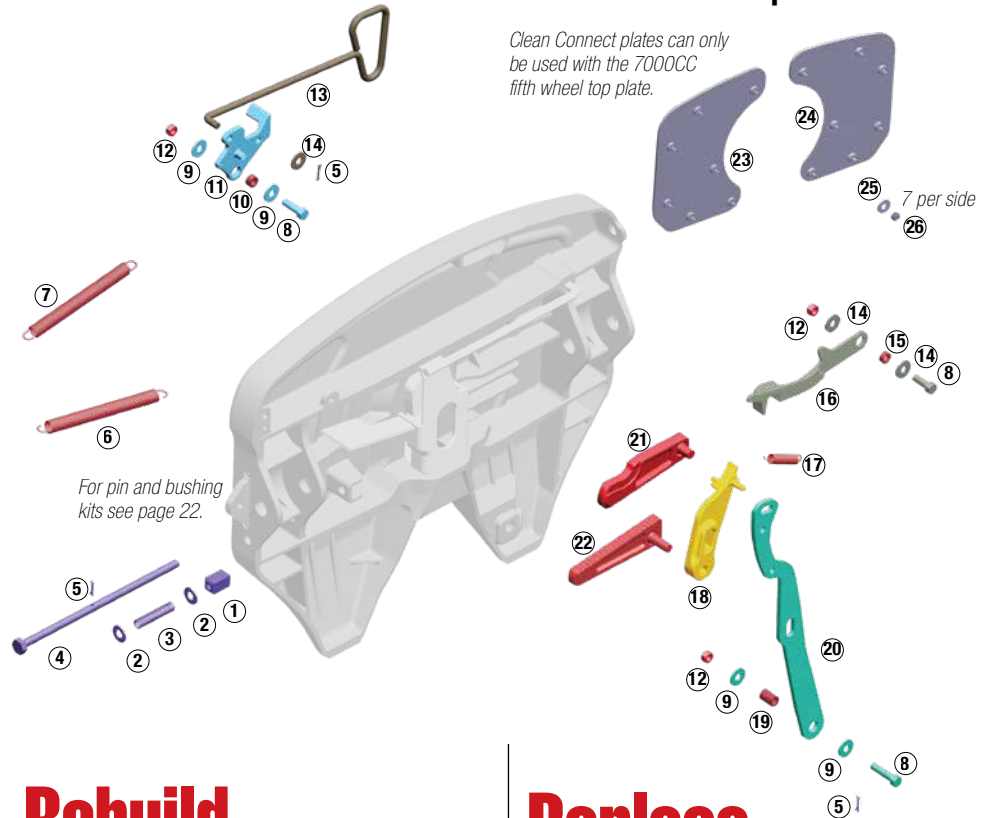

Clean Connect plates can only be used with the 7000CC fifth wheel top plate.

For pin and bushing kits see page 22.

Rebuild

Part number: KIT-RX-67NTL

Major rebuild kit for left side (driver) handle release NT/6000/7000/7000CC.

Kit does not include bracket pins, bushings or Clean Connect plate kits.



Part number: KIT-RX-67NTR

Major rebuild kit for right side (passenger) handle release NT/6000/7000/7000CC.

Kit does not include bracket pins, bushings or Clean Connect plate kits.



7000CC Options

Item	Description	Qty.
Clean Connect plate kits (7000CC)		
(CCR-PLATES-R)		
⑳	Right CC plate	1
㉑	Flat washer	7
㉒	Hex lock nut	7
(CCR-PLATES-L)		
㉑	Left CC plate	1
㉑	Flat washer	7
㉒	Hex lock nut	7

Replace

Replace or upgrade your fifth wheel top plate.



SLTPL7000 (Driver side)
AATPL7000 (Air Actuated)

No-Slack® 7000 Cast

Rated for moderate duty on both on-highway and off-highway applications



SLTPL6000 (Driver side)
AATPL6000 (Air Actuated)

No-Slack® 6000 Stamped Steel

Rated for standard to moderate duty on-highway



SLTPL7000CC (Driver side)
AATPL7000CC (Air Actuated)

No-Slack® 7000CC Clean Connect Cast

Rated for moderate duty for on-highway applications

NT top plates have been discontinued, however, repair kits are still available.

For replacement, order 6000 assemblies with proper mount for your application.

For pin and bushing kits see pages 22.

*Works for driver and passenger side models.

No-Slack® NT/6000/7000/7000CC No-Slack® Top Plate Kits

Repair

**Repair kit (Driver side: KIT-RPR-6000L,
Passenger side: KIT-RPR-6000R)**



Item	Qty.
Bumper spring	1
Handle spring	1
Timer spring	1
Step jaw	1
Wedge	1
Bushing, 7/16"	1
Bushing, 5/16"	1
Bushing, 1 1/4"	1
Hex lock nut, 1/2" - 13	3

Secondary lock kit (KIT-LAT-6000L)



Item	Qty.
Handle spring	1
Hex head bolt, 1/2" - 13	1
Flat washer, 1/2" I.D.	2
Bushing, 7/16"	1
Secondary lock	1
Hex lock nut, 1/2" - 13	1
Cotter pin, 3/16" x 1"	1

**Pull handle kit (Driver side: KIT-PUL-6000L,
Passenger side: KIT-RPR-6000R)**



Item	Qty.
Pull handle	1
Flat washer, 1/2" I.D.	1
Cotter pin, 3/16" x 1"	1

For H7 pull handle
see page 8.

Timer kit (KIT-TMR-6000L)



Item	Qty.
Timer spring	1
Timer	1
Hex lock nut, 1/2" - 13	1
Hair pin cotter	1

Air actuated kit

Part number:
KIT-AA-6000L

Description

Description	Quantity
① Air Cylinder	1
② Clevis Pin Long	1
③ Clevis Pin Short	1
④ Springs	2
⑤ Flat Washer 1/2"	2
⑥ Cotter Pin 5/32"	2
⑦ Exhaust Valve	1
⑧ Quick Disconnect Valve	1

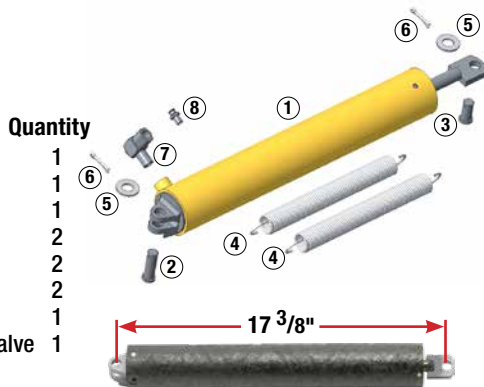

1/2" diameter holes

Wedge-stop rod kit (KIT-ROD-1108)



Item	Qty.
Wedge-stop rod nut	1
Flat washer, 5/8" I.D.	2
Wedge-stop rod spring	1
Wedge-stop rod	1
Cotter pin, 3/16" x 1"	1

Spring kit (KIT-SPRING)



Item	Qty.
Bumper/handle spring	2
Timer spring	1

Bumper kit (KIT-BPR-6000L)



Item	Qty.
Hex lock nut, 1/2" - 13	1
Flat washer, 1/2" I.D.	2
Bushing	1
Hex head bolt, 1/2" - 13	1
Bumper	1
Bumper spring	1

Operating handle kit (KIT-OPR-6000)



Item	Qty.
Bushing, 7/16"	1
Bushing, 5/16"	1
Bushing, 1 1/4"	1
Hex lock nut, 1/2" - 13	3
Flat washer, 1/2" I.D.	2
Hex head bolt, 1/2" - 13	1
Operating handle	1
Hair pin cotter	1

For H7 operating
handle see page 8.

Part number:

KITKPT

Test kingpin is an excellent tool
for jaw and wedge adjustment
(see page 26).



After a rebuild don't forget
to properly adjust your fifth
wheel. See page 26.

FONTAINE
FIFTH WHEEL®

No-Slack® H7 Heavy Duty Series

No-Slack® Top Plate Kits

Repair

Repair kit (KIT-RPR-6000L)

Item	Description	Qty.
⑥	Bumper spring	1
⑦	Handle spring	1
⑰	Timer spring	1
⑳	Step jaw	1
㉒	Wedge	1
⑩	Bushing, 7/16"	1
⑮	Bushing, 5/16"	1
⑲	Bushing, 1 1/4"	1
⑫	Hex lock nut, 1/2" - 13	3

Spring kit (KIT-SPRING)

⑥	Bumper spring	1
⑦	Handle spring	1
⑰	Timer spring	1

Wedge-stop rod kit (KIT-ROD-1108)

①	Wedge-stop rod nut	1
②	Flat washer, 5/8" I.D.	2
③	Wedge-stop rod spring	1
④	Wedge-stop rod	1
⑤	Cotter pin, 3/16" x 1"	1

Secondary lock kit (KIT-LAT-6000L)

⑦	Handle spring	1
⑧	Hex head bolt, 1/2" - 13	1
⑨	Flat washer, 1/2" I.D.	2
⑩	Bushing, 7/16"	1
⑪	Secondary lock	1
⑫	Hex lock nut, 1/2" - 13	1
⑤	Cotter pin, 3/16" x 1"	1

Pull handle kit (KITPULH7)

⑬	Heavy Duty Pull Handle	1
⑫	Hex lock nut, 1/2" - 13	1

Bumper kit (KIT-BPR-6000L)

⑫	Hex lock nut, 1/2" - 13	1
⑭	Flat washer, 1/2" I.D.	2
⑮	Bushing	1
⑧	Hex head bolt, 1/2" - 13	1
⑯	Bumper	1
⑥	Bumper spring	1

Timer kit (KIT-TMR-6000L)

⑰	Timer spring	1
⑱	Timer	1
⑫	Hex lock nut, 1/2" - 13	1
⑤	Hair pin cotter	1

Operating handle kit (KITOPRH7)

⑩	Bushing, 7/16"	1
⑮	Bushing, 5/16"	1
⑲	Bushing, 9/16"	1
⑫	Hex lock nut, 1/2" - 13	3
⑨	Flat washer, 1/2" I.D.	2
⑧	Hex head bolt, 1/2" - 13	1
⑳	Operating Handle	1
⑤	Hair pin cotter	1

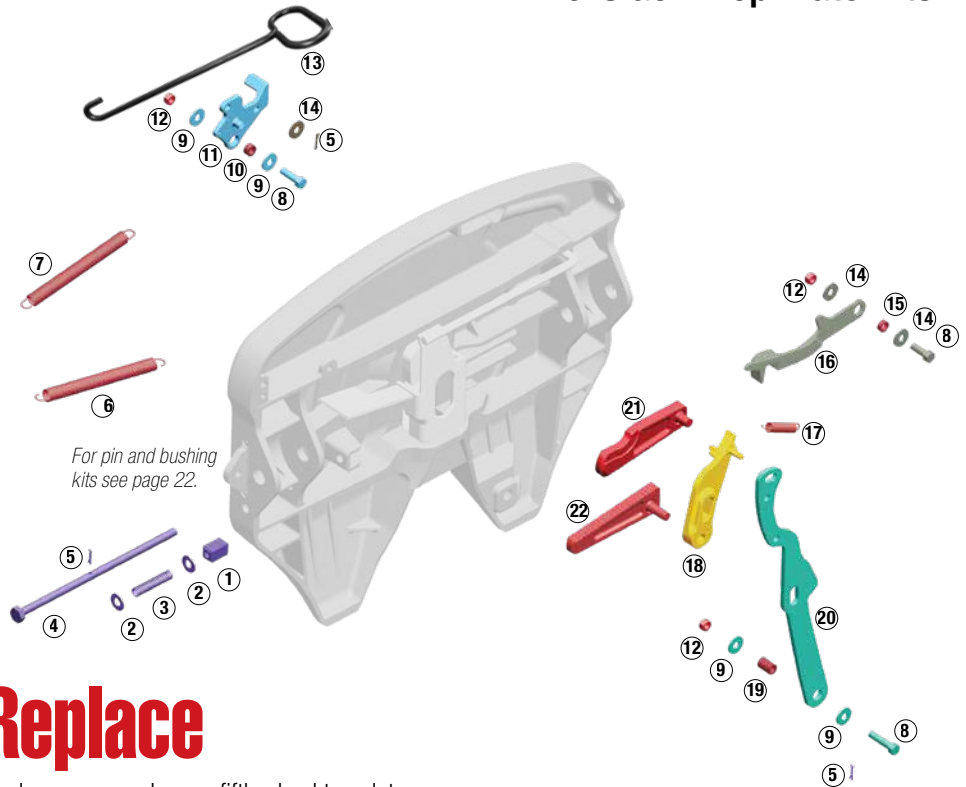

For pin and bushing kits see page 22.

Replace

Replace or upgrade your fifth wheel top plate.



SLTPLH7 (Driver side)

No-Slack® H7 Heavy Duty Steel reinforced cast housing

Rated for extra heavy-duty to severe-duty in both on-highway and off-highway applications. It's also available as a blocked fifth wheel to accommodate frameless dump applications.

H7 is the recommended replacement for H5092 and X5092

H7 Repair Kits

With the exception of the two kits below, H7 uses same kits as No-Slack on page 6.

Operating handle kit (KITOPRH7)



Item	Qty.
Bushing, 7/16"	1
Bushing, 5/16"	1
Bushing, 9/16"	1
Hex lock nut, 1/2" - 13	3
Flat washer, 1/2" I.D.	2
Hex head bolt, 1/2" - 13	1
Heavy Duty Operating Handle	1
Hair pin cotter	1

Pull handle kit (KITPULH7)



Item	Qty.
Heavy Duty Pull Handle	1
Hex lock nut, 1/2" - 13	1

No-Slack® H5092/X5092 Heavy Duty Series No-Slack® Top Plate Kits

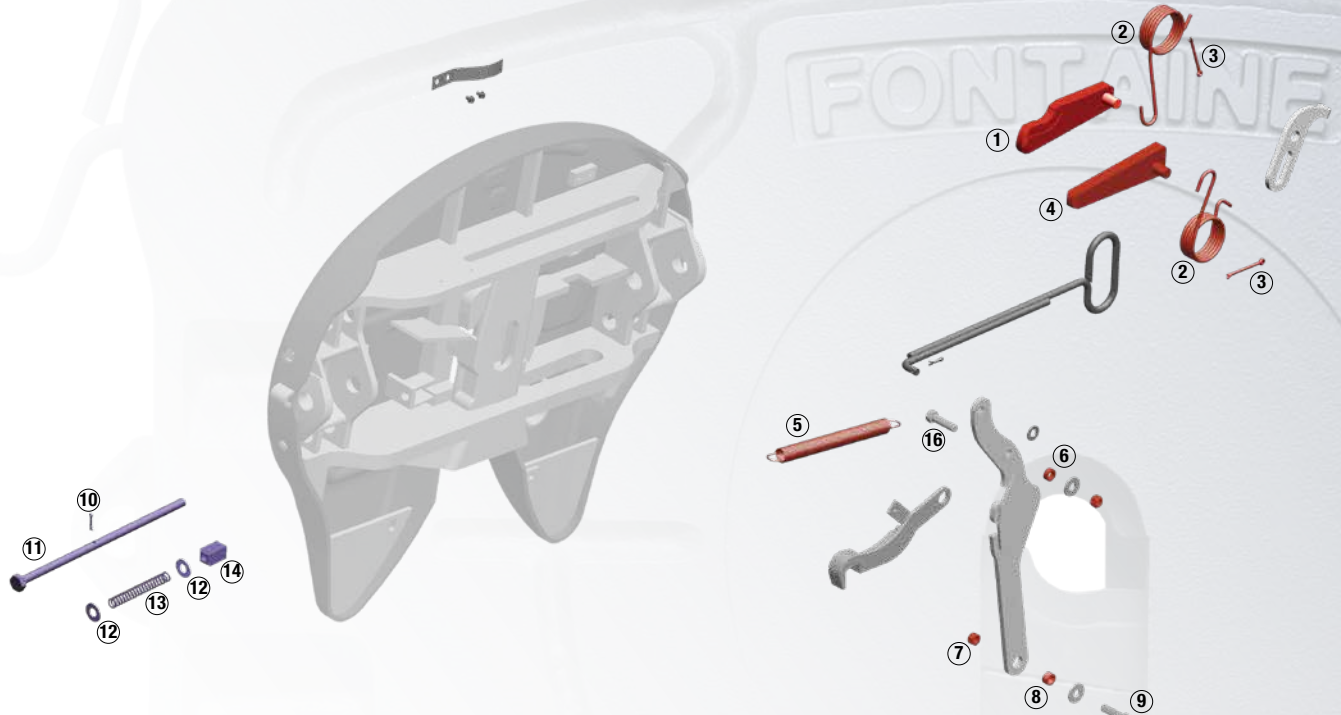

Repair

Repair kit (KIT-RPR-5092L or R)

Item	Description	Qty.
①	Step jaw	1
②	Jaw and wedge spring	2
③	Cotter pin, 1/4" x 3"	2
④	Wedge	1
⑤	Bumper spring	1
⑥	Bushing, 5/16"	1
⑦	Hex lock nut, 1/2" - 13	1
⑧	Bushing, 7/16"	1
⑨	Hex lock nut, 1/2" - 13	1



Wedge-stop rod kit (KIT-ROD-1108)

Item	Description	Quan.
⑩	Cotter pin, 3/16" x 1"	1
⑪	Wedge-stop rod	1
⑫	Flat washer, 5/8" I.D.	2
⑬	Wedge-stop rod spring	1
⑭	Wedge-stop rod nut	1



Rebuild

Part number: KIT-RX-5092L

Major rebuild kit for left side (driver) handle release H5092 and X5092 top plates.

Kit does not include bracket pins, bushings.



- Multiple kits combined in one saves you money
- Parts are arranged in the sequence you need them
- Complete instructions and link to video to make rebuild easy
- Reduce inventory
- Keep all the benefits of No-Slack® technology

Replace



SLTPLH7 (Driver side)

No-Slack® H7 Heavy Duty Steel reinforced cast housing

Rated for extra heavy-duty to severe-duty in both on-highway and off-highway applications. It's also available as a blocked fifth wheel to accommodate frameless dump applications.

H7 is the recommended replacement for H5092 and X5092

- Excellent replacement for H5092 and X5092 fifth wheel top plates
- Mounts on existing H5092/X5092 slides and brackets
- 62,500 lbs to 70,000 lbs vertical load
- 150,000 lbs to 200,000 lbs drawbar pull
- Improved No-Slack® locking mechanism

H5092 and X5092 top plates have been discontinued, however, parts are still available



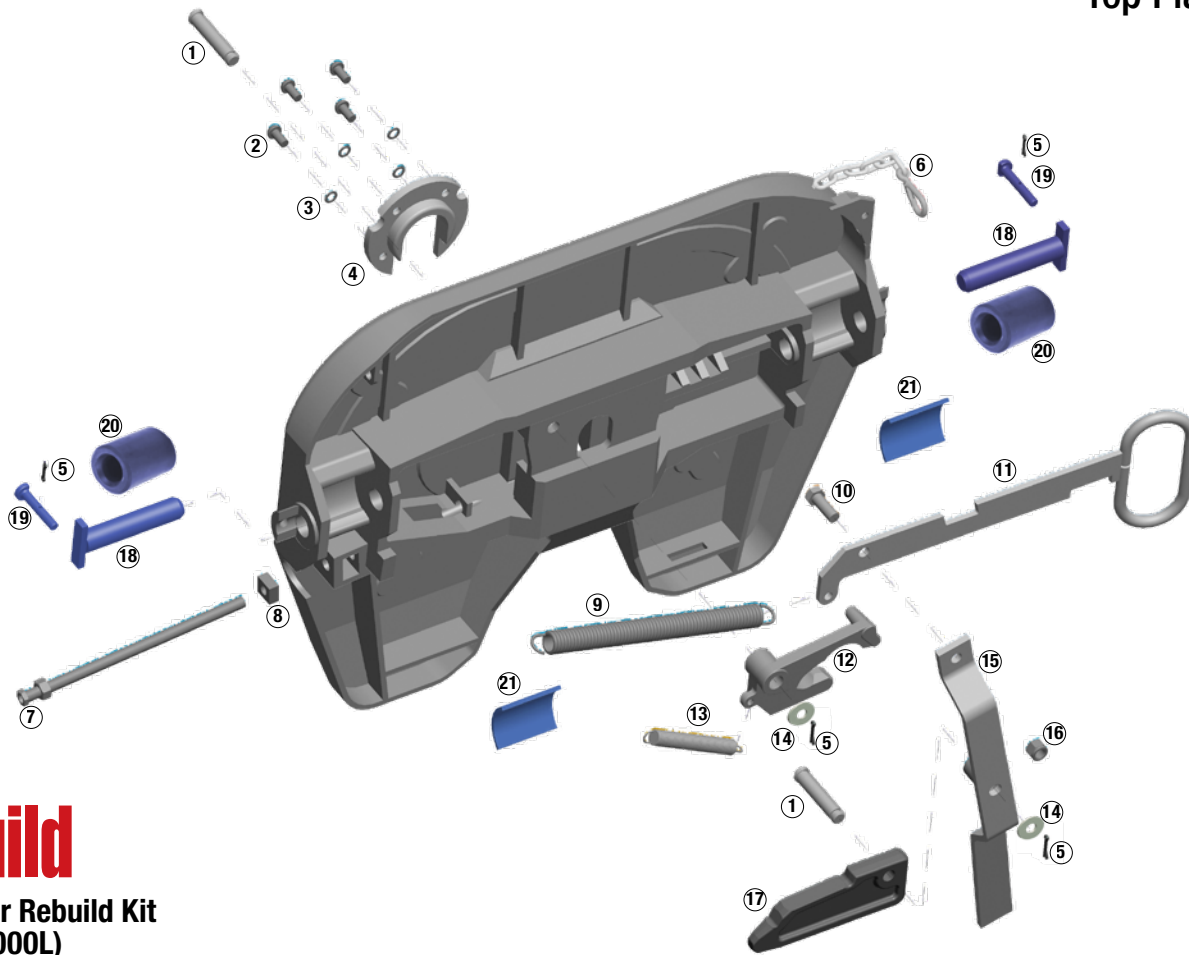

Rebuild

3000 Major Rebuild Kit (KIT-RX-3000L)



Item	Description	Qty.
①	Pivot Pin	2
②	Hex Socket Button Head Screw, M12X25MM	4
③	Flat Washer, M12	4
④	Wear Ring	1
⑤	Cotter Pin	2
⑥	Security Clip	1
⑦	Adjustment Rod	1
⑧	Adjustment Rod Nut, M16 Square	1
⑨	Main Spring	1
⑩	Hex Head Bolt, M16 X 40MM	1
⑪	Pull Handle	1
⑫	Rotating Locking Jaw	1
⑬	Jaw Spring	1
⑭	Washer, 3/4"	2
⑮	Operating Handle	1
⑯	Nylok Nut, M16	1
⑰	Locking Wedge	1

Replace

3000 and NT top plates have been discontinued, however, repair kits are still available.

For replacement, order 6000 assemblies with proper mount for your application.

Pin and Bushing Kit (KIT-PIN-3000)

Item	Description	Qty.
⑤	Cotter pin	2
⑰	Bracket liners	2
⑱	Bracket pin	2
⑲	Bracket retainer pin	2
⑳	1-piece bushing	2

CD700 Series Custom Duty Top Plate Kits

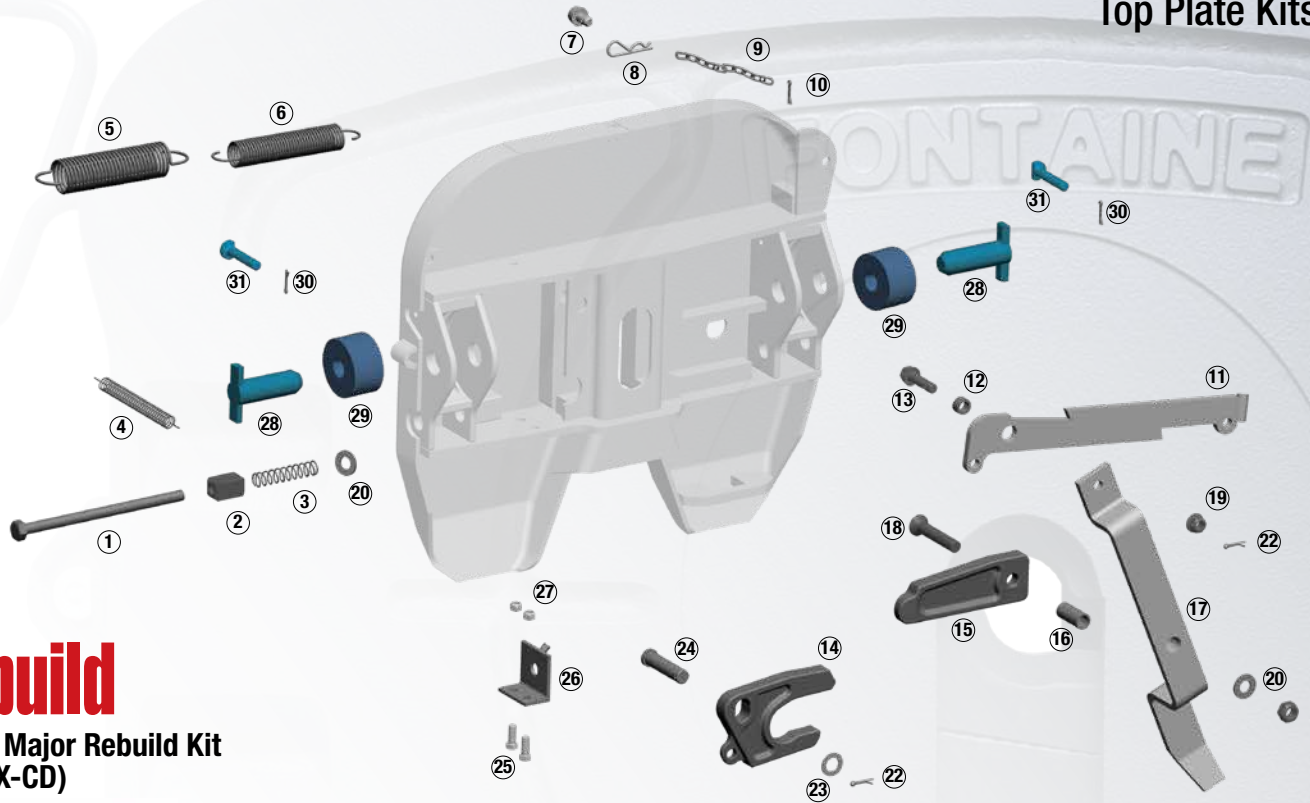

Rebuild

CD700 Major Rebuild Kit (KIT-RX-CD)



Item	Description	Quantity
①	Wedge-stop rod	1
②	Wedge-stop rod nut	1
③	Wedge-stop rod spring	1
④	Jaw spring	1
⑤	Pull handle spring 6.7" x 1.8"	1
⑥	Pull handle spring 6.75" x 1.35"	1
⑦	Handle lock pin	1
⑧	Hairpin cotter	1
⑨	Chain	1
⑩	Cotter pin, 3/16" x 1"	1
⑪	Pull handle	1
⑫	Bushing, 7/16"	1
⑬	Hex head flanged bolt, nut	1
⑭	Jaw	1
⑮	Wedge	1
⑯	Bushing	1
⑰	Operating handle	1
⑱	Flat head socket, 5/8"-11 x 3-1/2"	1
⑲	Flanged Hex Locknut 1/2" - 13	1
⑳	Flat washer, 5/8", plain	1
㉑	Hex lock nut, 5/8" -11, grade "B"	1
㉒	Cotter pin, 5/32" x 1"	2
㉓	Flat washer 3/4", plain	1
㉔	Clevis pin, 3/4" x 3"	1
㉕	Flat head bolt, 5/8-11 x 3-1/2"	2
㉖	Rod guide	1
㉗	Hex lock nut, 3/8"-16	2

Replace



SLTPLCD700-D5 (Driver side release)

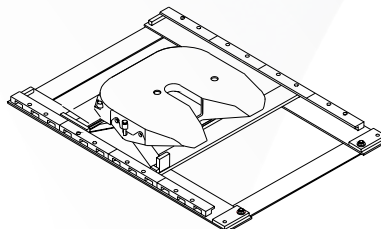

Complete Air Slide Assembly
CD7AWB675024
6 3/4" height
24-inch slide travel

Complete Stationary Assembly
SLCD7FM5750
Stationary 5 3/4" inch height
Weld on option"

Pin and Bushing Kit (KIT-CD-PIN-224)

Item	Description	Quantity
⑳	Bracket pin	2
㉑	Bracket bushing	2
㉒	Cotter pin, 3/16" x 1"	2
㉓	Bracket retainer pin	2

Custom Duty Service Parts

Stationary mount components

BKTCB (Pair) Bracket for the SLCD7FM5750

Slide mount components for AWB

CDBKTAWB6PT CD air slide bracket 6.75" height

CDSL24B 24" CD side rail

CYL-COMP AWB air cylinder

KITRPAWB Locking wedge (pair)



Complete Fifth Wheel Assemblies

Slides

No-Slack® 6NWB



No-Slack® 6000
50,000 pounds vertical load

Part Number	Fifth Wheel Height	Slide Length	Weight
SL6NWB675012	6-3/4"	12"	372 lbs
SL6NWB675024		24"	393 lbs
SL6NWB775012	7-3/4"	12"	378 lbs
SL6NWB775024		24"	399 lbs
SL6NWB875012	8-3/4"	12"	383 lbs
SL6NWB875024		24"	404 lbs

No-Slack® LWB



6000
50,000 pounds vertical load



7000
55,000 pounds vertical load



7000CC Clean Connect
55,000 pounds vertical load

6000 LWB Part Number	7000 LWB Part Number (Add 36 lbs)	7000CC LWB Part Number (Add 39 lbs)	Fifth Wheel Height	Slide Length	6000 Weight
SL6LWB675012	SL7LWB675012	SLCLWB675012	6-3/4"	12"	402 lbs
SL6LWB675016	SL7LWB675016	SLCLWB675016		16"	416 lbs
SL6LWB675024	SL7LWB675024	SLCLWB675024		24"	422 lbs
SL6LWB675036	SL7LWB675036	SLCLWB675036		36"	450 lbs
SL6LWB675048	SL7LWB675048	SLCLWB675048	7-1/4"	48"	472 lbs
SL6LWB725012	SL7LWB725012	SLCLWB725012		12"	405 lbs
SL6LWB725016	SL7LWB725016	SLCLWB725016		16"	419 lbs
SL6LWB725024	SL7LWB725024	SLCLWB725024		24"	425 lbs
SL6LWB725036	SL7LWB725036	SLCLWB725036	8-1/4"	36"	453 lbs
SL6LWB725048	SL7LWB725048	SLCLWB725048		48"	475 lbs
SL6LWB825012	SL7LWB825012	SLCLWB825012		12"	410 lbs
SL6LWB825016	SL7LWB825016	SLCLWB825016		16"	424 lbs
SL6LWB825024	SL7LWB825024	SLCLWB825024	9-1/4"	24"	430 lbs
SL6LWB825036	SL7LWB825036	SLCLWB825036		36"	458 lbs
SL6LWB825048	SL7LWB825048	SLCLWB825048		48"	480 lbs
SL6LWB925012	SL7LWB925012	SLCLWB925012		12"	415 lbs
SL6LWB925016	SL7LWB925016	SLCLWB925016	10-1/4"	16"	429 lbs
SL6LWB925024	SL7LWB925024	SLCLWB925024		24"	435 lbs
SL6LWB925036	SL7LWB925036	SLCLWB925036		36"	463 lbs
SL6LWB925048	SL7LWB925048	SLCLWB925048		48"	485 lbs
SL6LWB1025012	SL7LWB1025012	SLCLWB1025012	10-1/4"	12"	420 lbs
SL6LWB1025016	SL7LWB1025016	SLCLWB1025016		16"	434 lbs
SL6LWB1025024	SL7LWB1025024	SLCLWB1025024		24"	440 lbs
SL6LWB1025036	SL7LWB1025036	SLCLWB1025036		36"	468 lbs
SL6LWB1025048	SL7LWB1025048	SLCLWB1025048	48"	490 lbs	

Slides (Continued)

No-Slack® H7AWB



H7
62,500 pounds vertical load
150,000 pounds drivebar pull

H7 AWB Part Number	Fifth Wheel Height	Slide Length	Weight
SLH7AWB775012	7-3/4"	12"	557 lbs
SLH7AWB775016		16"	564 lbs
SLH7AWB775024		24"	572 lbs
SLH7AWB775036		36"	591 lbs
SLH7AWB775048	8-3/4"	48"	626 lbs
SLH7AWB875012		12"	563 lbs
SLH7AWB875016		16"	570 lbs
SLH7AWB875024		24"	578 lbs
SLH7AWB875036	9-3/4"	36"	597 lbs
SLH7AWB875048		48"	632 lbs
SLH7AWB975012		12"	569 lbs
SLH7AWB975016		16"	576 lbs
SLH7AWB975024	10-3/4"	24"	584 lbs
SLH7AWB975036		36"	603 lbs
SLH7AWB975048		48"	638 lbs
SLH7AWB1075012		12"	589 lbs
SLH7AWB1075016	10-3/4"	16"	596 lbs
SLH7AWB1075024		24"	604 lbs
SLH7AWB1075036		36"	623 lbs
SLH7AWB1075048		48"	658 lbs

Fixed Mount

No-Slack® FMA



7000
55,000 pounds vertical load

7000 FMA Part Number	Fifth Wheel Height	Weight
SL7FMA-D69-1	6-3/8"	329 lbs
SL7FMA-D69-2	7-3/8"	337 lbs
SL7FMA-D69-3	8-3/8"	345 lbs

No-Slack® BSL



6000
50,000 pounds vertical load



7000
55,000 pounds vertical load



7000CC Clean Connect
55,000 pounds vertical load

6000 BSL Part Number	7000 BSL Part Number (Add 39 lbs)	7000CC BSL Part Number (Add 42 lbs)	Fifth Wheel Height	6000 Weight
SL6BSL5375	SL7BSL5375	SLCBSL5375	5-3/8"	226 lbs
SL6BSL5875	SL7BSL5875	SLCBSL5875	5-7/8"	228 lbs
SL6BSL6875	SL7BSL6875	SLCBSL6875	6-7/8"	233 lbs
SL6BSL7875	SL7BSL7875	SLCBSL7875	7-7/8"	239 lbs
SL6BSL8875	SL7BSL8875	SLCBSL8875	8-7/8"	246 lbs
SL6BSL9875	SL7BSL9875	SLCBSL9875	9-7/8"	253 lbs

NEW 5-YEAR WARRANTY!

Complete Fifth Wheel Assemblies

Plate Mounts

No-Slack® PML



6000

50,000 pounds
vertical load



7000

55,000 pounds
vertical load



7000CC

55,000 pounds
vertical load

6000 PML Part Number	7000 PML Part Number (Add 39 lbs)	7000CC PML Part Number (Add 42 lbs)	Fifth Wheel Height	6000 Weight
SL6PML6250	SL7PML6250	SLCPML6250	6-1/4"	279 lbs
SL6PML7250	SL7PML7250	SLCPML7250	7-1/4"	286 lbs
SL6PML8250	SL7PML8250	SLCPML8250	8-1/4"	294 lbs
SL6PML9250	SL7PML9250	SLCPML9250	9-1/4"	299 lbs
SL6PML10250	SL7PML10250	SLCPML10250	10-1/4"	325 lbs

No-Slack® PMH and PMX



H7

70,000 pounds vertical load
200,000 pounds drivebar pull

H7PMH 39 1/2" wide (37 1/4" bolt centers)

PMH Standard adjustable stationary plate

Part Number	Fifth Wheel Height	Weight
SLH7PMH7500	7-1/2"	459 lbs
SLH7PMH8500	8-1/2"	465 lbs
SLH7PMH9500	9-1/2"	472 lbs

PMH Blocked (Tilt/No-Tilt) stationary adjustable plate

BLH7PMH7500	7-1/2"	467 lbs
BLH7PMH8500	8-1/2"	473 lbs
BLH7PMH9500	9-1/2"	480 lbs



H7

70,000 pounds vertical load
200,000 pounds drivebar pull

H7PMX 40 1/2" wide (38" bolt centers)

PMX Standard adjustable stationary plate

Part Number	Fifth Wheel Height	Weight
SLH7PMX7500	7-1/2"	464 lbs
SLH7PMX8500	8-1/2"	470 lbs
SLH7PMX9500	9-1/2"	477 lbs

PMX Blocked (Tilt/No-Tilt) stationary adjustable plate

BLH7PMX7500	7-1/2"	472 lbs
BLH7PMX8500	8-1/2"	478 lbs
BLH7PMX9500	9-1/2"	485 lbs

No-Slack® H7 PS5



H7

70,000 pounds vertical load
200,000 pounds drivebar pull

H7 PS5 Part Number	Fifth Wheel Height	Weight
SLH7PS58375	8-3/8"	500 lbs
SLH7PS59375	9-3/8"	504 lbs
SLH7PS510375	10-3/8"	508 lbs
SLH7PS511375	11-3/8"	526 lbs

www.fifthwheel.com/convert

You asked ... we listened.
The Fontaine competitor cross reference tool is here!

Replacing your Holland® or Jost® complete assembly with Fontaine has never been easier

NO-SLACK
CONVERSION CENTER

Enter Holland or Jost complete assembly part# [Find my No-Slack®](#)

Try it for yourself

CROSS reference

FONTAINE
FIFTH WHEEL



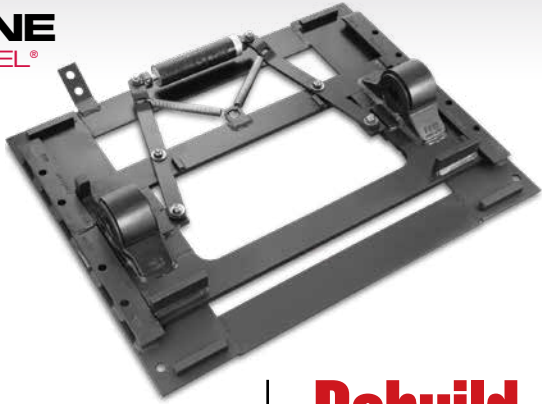

NWB Light Weight Standard duty air slide bracket and rails

Repair

Bracket pin kit (KIT-PIN-LLB)

Item Description	Qty.
Lower bracket bushing	2
Upper bracket bushing	2
Bracket pin	2
Bracket retainer pin	2
Cotter pin	2
Bracket liner	2



Bushing kit (BSH-LLB)

Lower bracket bushing	2
Upper bracket bushing	2
Bracket liner	2



Repair kit (KITRPRNWB)

① 1/2" x 1-3/4" screw	2
② Spacer bushing	2
③ 1/2" washer	2
④ 1/2" hex lock nut	2
⑦ Spring	2
⑥ Locking wedge	2

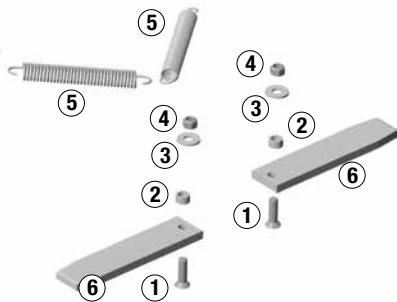

Rebuild

Rebuild kit (KITRXNWB)

Item Description	Qty.
① 1/2" x 1-3/4" screw	4
② Spacer bushing	6
③ 1/2" washer	4
④ 1/2" hex lock nut	6
⑤ 1/2" x 1-1/2" hex bolt	2
⑥ Locking wedge	2
⑦ Spring	2
⑧ Linkage	2
⑨ Composite Air Cylinder	1

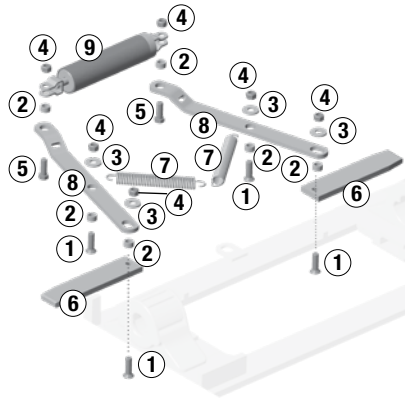

Mounting bolt kit (KIT-BOLT-24)

Kit includes mounting hardware you need to install any Fontaine 12" or 24" inch sliding mount to the trucks outboard angles (includes 20 Grade 8 bolts with matching locknuts and 40 hardened washers).



Replace

Cylinder kit (CYLNWB)

Item Description	Qty.
② Spacer bushing	2
④ 1/2" 13 Grade C hex lock nut	2
⑤ 1/2" x 1-1/2" hex bolt	2
⑨ Composite Air Cylinder	1

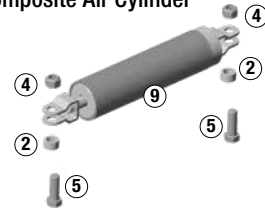

Air slide bracket

Part Number

BKTNWB6PT

BKTNWB67T

BKTNWB8PT

Mounted Height*

6-3/4"

7-3/4"

8-3/4"

*Height is measured from top of truck frame to top of fifth wheel

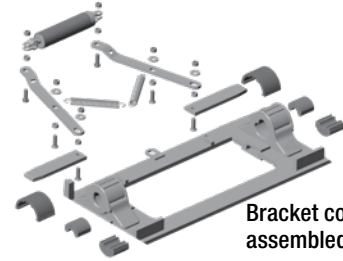

Slide rails

Part Number

SLRNWB-12

SLRNWB-24

Slide Travel

12"

24"

Overall Length

31"

43"



LWB Light Weight Standard duty air slide bracket and rails

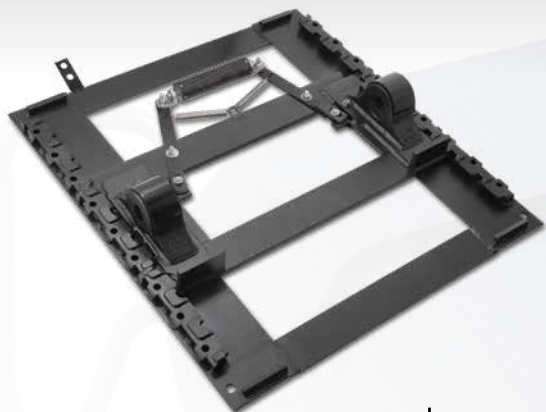

Replace

Replacement kit (KITRXLWB)

Item	Description	Qty.
①	Hex head bolt, 1/2"-13 x 1-1/2"	2
②	Flat head screw, 1/2"-13 x 1-3/4"	4
③	Washer, 1/2" type A plain	4
④	Spacer bushing	6
⑤	Extension spring	2
⑥	Hex nut, lock 1/2"-13	6
⑦	Locking wedge, left	1
⑧	Locking wedge, right	1
⑨	LWB slide bracket linkage	2
⑩	NWB/LWB air cylinder	1

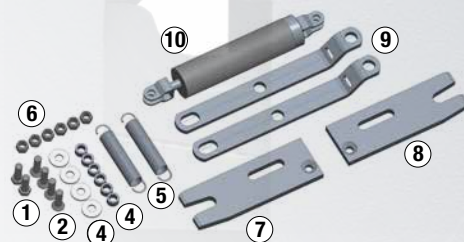

Air slide bracket Part Number	Mounted Height
BKTLWB6PT	6-3/4"
BKTLWB7PT	7-1/4"
BKTLWB8PT	8-1/4"
BKTLWB9PT	9-1/4"
BKTLWB10PT	10-1/4"

*Height is measured from top of truck frame to top of fifth wheel



Bracket comes assembled

Slide rails Part Number	Slide Travel	Overall Length
SLRLWB-12	12"	33"
SLRLWB-16	16"	39"
SLRLWB-24	24"	45"
SLRLWB-36	36"	57"
SLRLWB-48	48"	69"

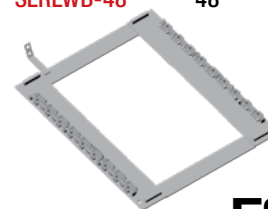

Repair

Bracket pin kit (KIT-PIN-LLB)

Item	Description	Qty.
Lower bracket bushing		2
Upper bracket bushing		2
Bracket pin		2
Bracket retainer pin		2
Cotter pin		2
Bracket liner		2



Bushing kit (BSH-LLB)

Lower bracket bushing	2
Upper bracket bushing	2
Bracket liner	2



Air cylinder kit (CYLLWB)

① Hex head bolt, 1/2"-13 x 1-1/2"	2
② Hex nut, lock 1/2"-13	2
③ Spacer bushing	2
④ NWB/LWB air cylinder	1
⑤ LWB/AFM double bend linkage	2

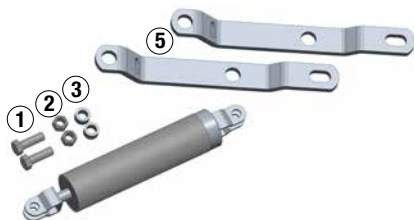

Rebuild

Rebuild kit (KITRPLWB)

① Extension spring, pull bar	2
② LWB/AFM flat slide linkage	2
③ RH LWB 2" AFM wedge	1
④ LH LWB 2" AFM wedge	1
⑤ Flat head screw 1/2-13 x 1-3/4"	2
⑥ Washer, 1/2" type A plain	2
⑦ Spacer bushing	2
⑧ Hex lock nut, 1/2-13	2



For more information
See TB-067

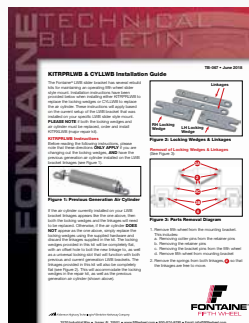

**KITRPLWB & CYLLWB
Installation Guide**
[www.fifthwheel.com/pdfs/
technicalbulletins/TB-067.pdf](http://www.fifthwheel.com/pdfs/technicalbulletins/TB-067.pdf)

Mounting bolt kit (KIT-BOLT-24)

Kit includes mounting hardware you need to install any Fontaine 12", 16" or 24" inch sliding mount to the trucks outboard angles (includes 20 Grade 8 bolts with matching locknuts and 40 hardened washers).



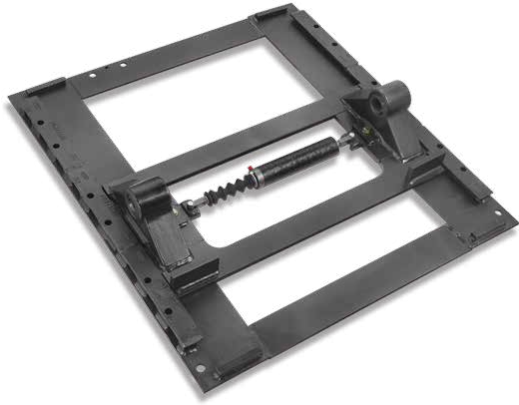

LWO Light Weight Standard duty air slide bracket and rails

Repair

**For No-Slack NT (UNT) Series
Top Plate Models**

Bracket pin kit (KIT-PIN-UNT)

Item	Qty.
1-piece bushing	2
Bracket pin	2
Bracket retainer pin	2
Cotter pin	2
Bracket Liner	2



**For 3000 Series
Top Plate Models**

Bracket pin kit (KIT-PIN-3000)

Item	Qty.
Bracket liners	2
1-piece bushing	2
Bracket pin	2
Bracket retainer pin	2
Cotter pin	2



Rebuild

Cylinder kit (KITRXLWO)

Item	Description	Qty.
①	Composite Air Cylinder	1
②	LWO slide wedges	2
③	Hex head bolt, 1/2"- 13 x 1"	2
④	Hex head bolt, 3/8"- 16 x 1 1/4"	2
⑤	Bushing	2
⑥	Hex locknut, 3/8"- 16	2
⑦	Flat washer 1/2"	2

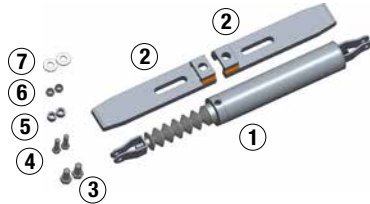

Replace

**6000 and 7000 series top
plates do not fit this slide
bracket**

**3000 and NT top plates
have been discontinued,
however, repair kits are still
available.**

**For replacement, order 6000
assemblies with proper
mount for your application.**



Repair

Bracket pin kit (KIT-PIN-LLB)

Item Description	Qty.
Lower bracket bushing	2
Upper bracket bushing	2
Bracket pin	2
Bracket retainer pin	2
Cotter pin	2
Bracket liner	2



Bushing kit (BSH-LLB)

Lower bracket bushing	2
Upper bracket bushing	2
Bracket liner	2



Repair kit (KITRPRATB)

③ Flat head socket, 1/2" -13 x 2"	2
⑤ Hex jam nut, 1/2" -13, NY	2
⑦ Flat washer, 1/2" Type A, .132	2
⑧ Spacer bushing	2
⑬ Locking wedge, slide assembly	2
⑭ Locking member spring	2

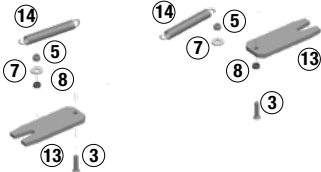

Cylinder kit (CYL-COMP)

Item Description	Qty.
⑩ Composite Air Cylinder	1
④ Flat head socket, 1/2" -13 x 1-1/2", grade 5	1
⑭ Flat washer, 1/2" I.D., 1-3/8" O.D., plain	2
⑫ Hex lock nut, 1/2" -13, grade "C"	2
⑮ Bushing, 7/16"	2

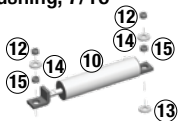

Reuse Hex bolt ①

Rebuild

Rebuild kit (KITRXATB)

Item Description	Qty.
① Spacer bushing	2
② Flat head socket, 1/2" -13 x 1-1/2"	2
③ Flat head socket, 1/2" -13 x 2"	3
④ Hex head bolt, 1/2" -13 x 1"	2
⑤ Hex jam nut, 1/2" -13, NY	5
⑥ Hex lock nut, 1/2" -13, grade "C"	2
⑦ Flat washer, 1/2" Type A, .132	8
⑧ Spacer bushing	5
⑨ Pull bar, slide bracket	1
⑩ Pull bar, slide bracket	1
⑪ Latching lever	1
⑫ Composite Air Cylinder	1
⑬ Locking wedge, slide assembly	2
⑭ Locking member spring	2

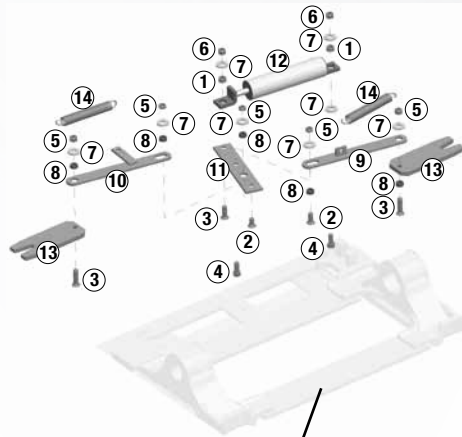

Bracket not included in kit

Mounting bolt kit (KIT-BOLT-24)

Kit includes mounting hardware you need to install any Fontaine 12", 16" or 24" inch sliding mount to the trucks outboard angles (includes 20 Grade 8 bolts with matching locknuts and 40 hardened washers).



Replace

Upgrade to the lighter LWB setup

Slide rails Part Number	Mounted Height*	Slide Travel	Overall Length
ASYLWB612	6.75"	12"	33"
ASYLWB624	6.75"	24"	45"
ASYLWB712	7.25"	12"	33"
ASYLWB716	7.25"	16"	39"
ASYLWB724	7.25"	24"	45"
ASYLWB736	7.25"	36"	57"
ASYLWB812	8.25"	12"	33"
ASYLWB816	8.25"	16"	39"
ASYLWB824	8.25"	24"	45"
ASYLWB912	9.25"	12"	33"
ASYLWB916	9.25"	16"	39"
ASYLWB924	9.25"	24"	45"
ASYLWB1012	10.25"	12"	33"
ASYLWB1016	10.25"	16"	39"
ASYLWB1024	10.25"	24"	45"

*Height is measured from top of truck frame to top of fifth wheel

All assembly part numbers include bracket and slide rail



For additional height and slide length options replacing the ATB, please email: Parts@fifthwheel.com



Repair

Bracket pin and bushing kit (KIT-PIN-191)

Item	Qty.
1-piece bushing	2
Bracket pin	2
Bracket retainer pin	2
Cotter pin	2



Bushing kit (BSH-150)

1-piece bushing



Repair kit (KITRPAWB)

③ Flat head socket, 1/2" -13 x 2", grade 5	2
⑤ Hex jam nut, 1/2" -13, NY	2
⑦ Flat washer, 1/2" I.D., .132 Type A	2
⑧ Spacer bushing	2
⑩ Locking wedge slide assembly	2
⑭ Locking member spring	2

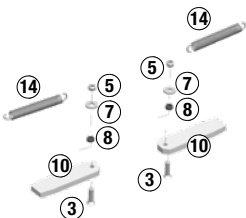

Rebuild

Rebuild kit (KITRXAWB)

Item Description	Qty.
① Spacer bushing	2
② B Flat head socket, 1/2" -13 x 1", grade 5	2
③ Flat head socket, 1/2" -13 x 2", grade 5	3
④ Hex head bolt, 1/2" -13 x 1.2", grade 5	1
⑤ Hex jam nut, 1/2" -13, NY	5
⑥ Hex lock nut, 1/2" -13, grade "C"	2
⑦ Flat washer, 1/2" I.D., .132 Type A	8
⑧ Spacer bushing	5
⑨ Pull bar slide bracket	1
⑩ Locking wedge slide assembly	2
⑪ Pull bar slide bracket	1
⑫ Latching Lever	1
⑬ Composite Air Cylinder	1
⑭ Locking member spring	2

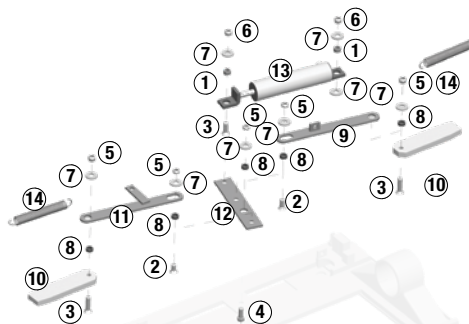

Mounting bolt kit (KIT-BOLT-24)

Kit includes mounting hardware you need to install any Fontaine 12", 16" or 24" inch sliding mount to the trucks outboard angles (includes 20 Grade 8 bolts with matching locknuts and 40 hardened washers).



Replace

Cylinder kit (CYL-COMP)

Item	Description	Qty.
①	Spacer bushing	2
⑬	Composite Air Cylinder	1
③	Flat head socket, 1/2" -13 x 1-1/2", grade 5	1
⑦	Flat washer, 1/2" I.D., .132 Type A	2
⑥	Hex lock nut, 1/2" -13, grade "C"	2

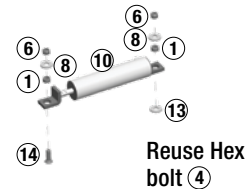

Air slide bracket

Part Number	Mounted Height*
BKTAWB6PT	6-3/4"
BKTAWB7PT	7-3/4"
BKTAWB8PT	8-3/4"
BKTAWB9PT	9-3/4"
BKTAWB10PT	10-3/4"

*Height is measured from top of truck frame to top of fifth wheel

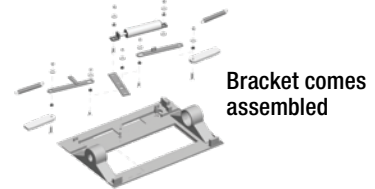

Slide rails

Part Number	Slide Travel	Overall Length
SLR12B	12"	42"
SLR16B	16"	46"
SLR24B	24"	54"
SLR36B	36"	66"
SLR48B	48"	78"

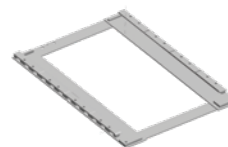

AWX

Extra heavy duty air slide bracket and rails

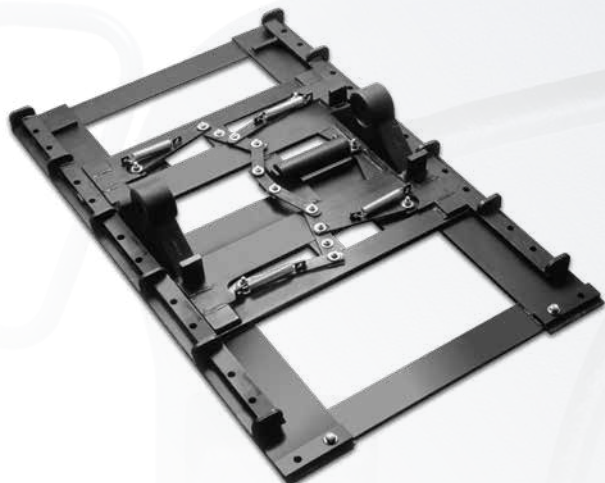

Repair

Bushing kit (BSH-150)

1-piece bushing



Repair kit (KITRPAWB)

2 required for AWX

- ③ Flat head socket, 1/2" -13 x 2", grade 5 2
- ⑤ Hex jam nut, 1/2" -13, NY 2
- ⑦ Flat washer, 1/2" I.D., .132 Type A 2
- ⑧ Spacer bushing 2
- ⑩ Locking wedge slide assembly 2
- ⑭ Locking member spring 2

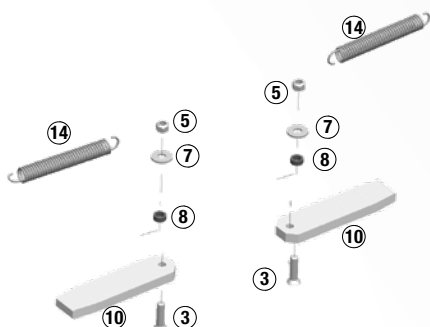

*To repair, use two
KITRPAWB for
double locks*

Replace

Cylinder kit (CYL-XAWX)

Item	Description	Qty.
①	Bushing, 5/16"	3
②	Hex Bolt, 1/2"-13 X 1"	2
③	Hex Bolt, 1/2"-13 X 1.5"	1
④	Hex jam nut, 1/2" -13, grade "B"	1
⑤	Hex lock nut, 1/2" -13, grade "C"	3
⑥	Washer 1/2"	3
⑦	XHD Air Cylinder	1

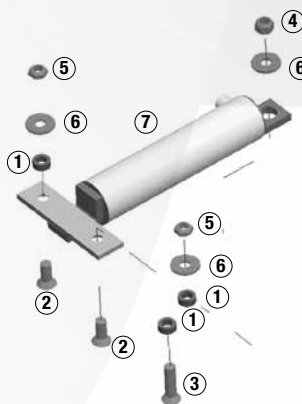

*Individual brackets and rails are obsolete, see
page 12-13 for complete assembly options.*



FMA-D3 fixed mount

FMA mounts (pairs) Part Number	Mounted height	Compatible Plates	Repair kits for FMA
BKT6FMA6375-D3*	.6-3/8"	SLTPL6000	Pins and bushingsKIT-PIN-191
BKT6FMA7375-D3*	.7-3/8"	SLTPL7000	Bushings BSH-150
BKT6FMA8375-D3	.8-3/8"	SLTPL7000CC	
BKT6FMA9375-D3	.9-3/8"		
BKT6FMA10375-D3	10-3/8"		

*6-3/8 and 7-3/8 are the only heights that include the front rocker limit blocks.



FMA-D3 models can be identified by the 4 bolt pattern.

The 6 bolt pattern FMA is now obsolete.

PML plate mount

PML mounts Part #	Mounted height	Compatible Plates	Repair kits for PML
ASYPML6250	.6-1/4"	SLTPL6000	Pins, bushings and KIT-PIN-LLB
ASYPML7250	.7-1/4"	SLTPL7000	bracket liners
ASYPML8250	.8-1/4"	SLTPL7000CC	Bushings BSH-LLB
ASYPML9250	.9-1/4"		
ASYPML10250	10-1/4"		

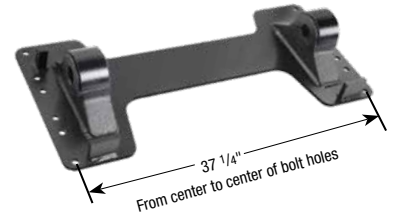

BSL welded fixed mount

BSL mounts (pairs) Part number	Mounted height	Compatible Plates	Repair kits for PML
BKTBSL5375	.5-3/8"	SLTPL6000	Pins, bushings and KIT-PIN-LLB
BKTBSL5875	.5-7/8"	SLTPL7000	bracket liners
BKTBSL6875	.6-7/8"	SLTPL7000CC	Bushings BSH-LLB
BKTBSL7875	.7-7/8"		
BKTBSL8875	.8-7/8"		
BKTBSL9875	.9-7/8"		

Note: Some welding required.

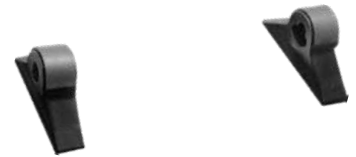

Stationary PS5 assembly

PS5 Mounts Part #	Mounted height	Compatible Plates	Repair kits for PML
ASYPS57375 ¹	.7-3/8"	SLTPL7000 ²	Pins, bushings and KIT-PIN-191
ASYPS58375	.8-3/8"	SLTPLH7	bracket liners
ASYPS59375	.9-3/8"		Bushings BSH-150
ASYPS510375	10-3/8"		
ASYPS511375	11-3/8"		

¹Fontaine H7 heavy duty top plate (SLTPLH7) will not work with 7.375 height.

²Use SLTPL7000 with 7-3/8" models. Use 8-3/8" to 11-3/8" models with SLTPLH7.

ASYPS58375 shown here.



Stationary PMH and PMX assemblies

Part #	Mounted height	Compatible Plates	Repair kits for PMH/PMX
ASYPMH7500	7-1/2"	SLTPLH7	Pins and bushings ... KIT-PIN-HDLLB
ASYPMH7500	8-1/2"		
ASYPMH7500	9-1/2"		
ASYPMX7500	7-1/2"		
ASYPMX7500	8-1/2"		
ASYPMX7500	9-1/2"		

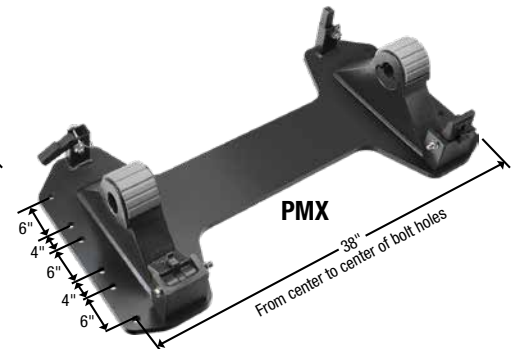
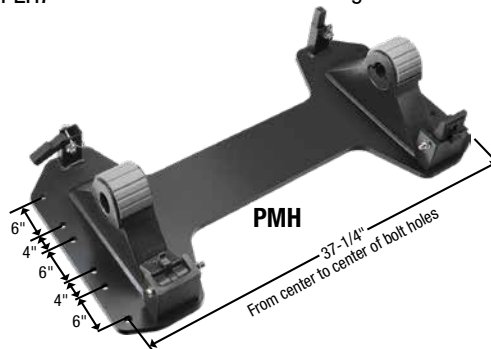

Blocked (No-Tilt) Fifth Wheels

BLH7AWB blocked air slide fifth wheels (Tilt/No-Tilt Option)

Blocked Complete Assemblies

H7 Blocked AWB Part Number	Fifth Wheel Height*	Slide Length	Weight
BLH7AWB775012	7-3/4"	12"	602 lbs
BLH7AWB775016		16"	610 lbs
BLH7AWB775024		24"	622 lbs
BLH7AWB775036		36"	642 lbs
BLH7AWB775048		48"	669 lbs
BLH7AWB875012		8-3/4"	12"
BLH7AWB875016	16"		619 lbs
BLH7AWB875024	24"		631 lbs
BLH7AWB875036	36"		651 lbs
BLH7AWB875048	48"		678 lbs

H7 Blocked AWB Part Number	Fifth Wheel Height	Slide Length	Weight
BLH7AWB975012	9-3/4"	12"	620 lbs
BLH7AWB975016		16"	628 lbs
BLH7AWB975024		24"	640 lbs
BLH7AWB975036		36"	660 lbs
BLH7AWB975048		48"	687 lbs
BLH7AWB1075012		10-3/4"	12"
BLH7AWB1075016	16"		651 lbs
BLH7AWB1075024	24"		663 lbs
BLH7AWB1075036	36"		683 lbs
BLH7AWB1075048	48"		710 lbs

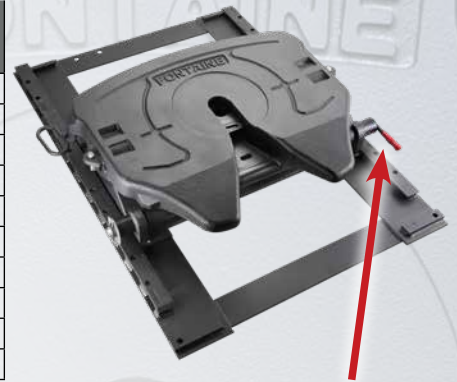

Removing blocking bar converts "No-Tilt" blocked fifth wheel to standard fifth wheel that can tilt.

Replacement Bar (For AWB and PS5 Brackets)

Replacement bar for Blocked H5092 and H7 top plate. BAR-396-BK
(For BLHAWB, BLHMWS and BLHPSA brackets)

BLH7PS5 blocked plate mount fifth wheels (Tilt/No-Tilt Option)

Blocked Complete Assemblies

H7 Blocked PS5 Part Number	Fifth Wheel Height	Weight
BLH7PS58375	8-3/8"	509 lbs
BLH7PS59375	9-3/8"	514 lbs
BLH7PS510375	10-3/8"	521 lbs
BLH7PS511375	11-3/8"	528 lbs



Removing blocking bar converts "No-Tilt" blocked fifth wheel to standard fifth wheel that can tilt.

BLPMH & BLPMX blocked plate mount fifth wheels (Tilt/No-Tilt Option)

Blocked Complete Assemblies

H7PMH 39 1/2" wide (37 1/4" bolt centers)

PMH Standard adjustable stationary plate

Part Number	Fifth Wheel Height	Weight
SLH7PMH7500	7-1/2"	459 lbs
SLH7PMH8500	8-1/2"	465 lbs
SLH7PMH9500	9-1/2"	472 lbs

PMH Blocked (Tilt/No-Tilt) stationary adjustable plate

BLH7PMH7500	7-1/2"	467 lbs
BLH7PMH8500	8-1/2"	473 lbs
BLH7PMH9500	9-1/2"	480 lbs

H7PMX 40 1/2" wide (38" bolt centers)

PMX Standard adjustable stationary plate

Part Number	Fifth Wheel Height	Weight
SLH7PMX7500	7-1/2"	464 lbs
SLH7PMX8500	8-1/2"	470 lbs
SLH7PMX9500	9-1/2"	477 lbs

PMX Blocked (Tilt/No-Tilt) stationary adjustable plate

BLH7PMX7500	7-1/2"	472 lbs
BLH7PMX8500	8-1/2"	478 lbs
BLH7PMX9500	9-1/2"	485 lbs



Pin and Bushing Kits

Bracket Pin and Bushing Kits

Bracket pin kit (KIT-PIN-LLB)



Item	Qty.
2-piece bushing	2 Pairs
Bracket pin	2
Bracket retainer pin	2
Cotter pin	2
Bracket liner	2

Bracket pin kit (KIT-PIN-191)



Item	Qty.
1-piece bushing	2
Bracket pin	2
Bracket retainer pin	2
Cotter pin	2

Bracket pin kit (KIT-PIN-UNT)



Item	Qty.
1-piece bushing	2
Bracket pin	2
Bracket retainer pin	2
Cotter pin	2
Bracket Liner	2

Bracket pin kit (KIT-PIN-3000)



Item	Qty.
Bracket liners	2
1-piece bushing	2
Bracket pin	2
Bracket retainer pin	2
Cotter pin	2

Bracket Pin and Bushing Kits (Continued)

Bracket pin kit (KIT-PIN-HDLLB)



Item	Qty.
2-piece bushing	2 Pairs
Bracket pin	2
Bracket retainer pin	2
Cotter pin	2
Bracket liner	2

Bushing Kits

Bushing kit (BSH-LLB)



Item	Qty.
2-piece bushing	2 Pairs
Bracket liner	2

Bushing kit (BSH-150)



Item	Qty.
1-piece bushing	2

Bracket Pin and Bushing Kit Guide

Top Plate Mount	Top Plate	Bracket Pin Kit	Bushing Kit
Sliding Brackets			
ATB	6000, 7000, 7000CC	KIT-PIN-LLB	BSH-LLB
AWB	7000, H5092, H7	KIT-PIN-191	BSH-150
AWB Blocked BLAWB	7000, H5092, H7	KIT-PIN-191	BSH-150
AWX	H5092, H7	-	BSH-150
LWB	6000, 7000, 7000CC	KIT-PIN-LLB	BSH-LLB
LWO	NT, 3000	KIT-PIN-UNT*	-
MTB	6000, 7000, 7000CC	KIT-PIN-LLB	BSH-LLB
MWS	H5092, H7	KIT-PIN-191	BSH-150
NWB	6000	KIT-PIN-LLB	BSH-LLB
XPSA	X5092	-	BSH-150
ASB	NT, 3000	KIT-PIN-3000	-

Top Plate Mount	Top Plate	Bracket Pin Kit	Bushing Kit
Fixed Mount/Plate Mount			
APB	NT, 3000	KIT-PIN-UNT*	-
BSL	6000, 7000, 7000CC	KIT-PIN-LLB	BSH-LLB
BSM	6000, 7000, 7000CC	KIT-PIN-LLB	BSH-LLB
FMA	6000, 7000, 7000CC	KIT-PIN-191	BSH-150
FMA D3	6000, 7000, 7000CC	KIT-PIN-191	BSH-150
PMA	6000, 7000, 7000CC	KIT-PIN-LLB	BSH-LLB
PML	6000, 7000, 7000CC	KIT-PIN-LLB	BSH-LLB
PSA	H5092, H7	KIT-PIN-191	BSH-150
PS5	H5092, H7	KIT-PIN-191	BSH-150
PS5 Blocked	H5092, H7	KIT-PIN-191	BSH-150
PMH and PMX	H7	KIT-PIN-HDLLB	-
PMH and PMX Blocked	H7	KIT-PIN-HDLLB	-
SMB	NT, 3000	KIT-PIN-UNT*	-
XPSA	X5092	-	BSH-150

*If 3000 Series top plate on the bracket or slide, use KIT-PIN-3000.

Important Application Notes

Top plate selection notes:

- For fifth wheel top plate selection guide see page 5. Air activated release styles are available on select models.

Mount selection notes:

- A sliding mount gives the owner more options. You can transfer weight between tractor axles, handle trailers with different kingpin settings, and vary vehicle combination lengths. A sliding mount fifth wheel also provides additional maneuverability, accommodates trailers with short landing gear clearance and allows the driver to extend the unit for maximum comfort when weight allows. If you choose a sliding mount, Fontaine offers a wide selection of slide lengths.

Stationary mount fifth wheels (plate or angle mounts) are an option and ideal for applications where the trailer kingpin position, kingpin weight, axle loading and vehicle length are constant or consistent when loaded. Stationary mount fifth wheels are usually lighter than sliding mount fifth wheels.

How to select fifth wheel



Choose "Support" menu, then "Choosing the right fifth wheel"

Important application notes:

- If any single restriction factor within your application is surpassed within a given duty level, the next duty level must be selected.
- For more information on standard, moderate and severe duty, please review the **duty class restrictions** on page 24.
- When selecting a fifth wheel, if the application or vehicle usage places the maximum capacity on a certain fifth wheel, then the selection of a fifth wheel with a higher capacity is advised. For example, a tractor that is at a maximum vertical load of 50,000 lbs in a moderate duty application should be using a fifth wheel with a vertical load capacity of 55,000 lbs or greater. This additional capacity should give better service life over a longer period of time.

Special applications:

- All logging, mining and oil field applications are considered severe duty. Do not select assemblies in the standard or moderate levels when a special application is designated.

Minimum static load warning:

- Minimum static load warning!!! The trailer that is attached to the fifth wheel should impose a consistent vertical load. Repeated negative loading (trying to pull the fifth wheel off of the brackets with the kingpin) is not allowed. A minimum static load applied to the fifth wheel through the trailer is 10% of the gross trailer weight. See the load rating for the specific fifth wheel for maximum vertical load values.



Van trailers



Tankers and bulk trailers



Flatbeds, stretch and stake trailers



Lowbed trailers



Framed end and frameless dump trailers

Important: Contact your OEM or Fontaine Fifth Wheel for more information on the right fifth wheel for your application. Please refer to the Fontaine Fifth Wheel warranty statement for important warranty information. Selecting assemblies in conflict with this application guide without prior written approval from Fontaine engineering voids all warranties. For more information about duty class restrictions and applications see LT-076: Application guide at fifthwheel.com in the Literature section. LT-001: Instruction manual is also available in the Literature section.



Duty Class Restrictions

With the Fontaine Fifth Wheel complete product line you can easily select the perfect fifth wheel for your application. We offer top plates and mounting options in a wide variety of sizes to handle even the most demanding applications.

To specify the right fifth wheel for your application two factors must be considered: load capacity and service conditions.

“Weight” refers to the amount of weight that a fifth wheel can handle. “Road type” refers to the operating environment and the type of equipment used in an application. “Travel type” refers to mileage between stops.

You don’t choose a top plate based on “weight” only. Consider service conditions because a heavy load pulled on a paved road places less stress on a fifth wheel than a lighter load pulled in severe off-highway conditions.

The duty class restriction chart at right and No-Slack® top plate options chart (page 5) can be used as a guide to help you select the right fifth wheel.

Fontaine has an application guide (LT-076) that can be obtained at: www.fifthwheel.com (Choose “Support” and then “Spec My Truck”).

If you need further assistance contact Fontaine Fifth Wheel at: 800-874-9780.



On-line selection guide is available. Scan code or go to: www.fifthwheel.com Choose “Support” then choose “Spec My Truck”

Standard Duty	
Weight:	Less than 95,000 lbs (43,000 kgs) gross combination weight (GCW)
Road type:	100% on-highway application on maintained concrete or asphalt roads
Travel type:	More than 30 miles between each couple
Axle limitation:	Maximum number of towed axles equals 3

Moderate Duty	
Weight:	Less than 115,000 lbs (52,000 kgs) gross combination weight (GCW)
Road type:	Less than 10% off-highway application on maintained concrete, asphalt, gravel or crushed rock roads
Travel type:	No minimum mileage between couples
Axle limitation:	Maximum number of towed axles equals 4

Heavy Duty	
Weight:	Less than 140,000 lbs. (63,500 kgs) gross combination weight (GCW)"
Road type:	Less than 10% off-highway application on maintained concrete, asphalt, gravel or crushed rock roads
Travel type:	No minimum mileage between couples.
Axle limitation:	No axle limitations

Severe Duty	
Weight:	More than 115,000 lbs. (52,000 kgs) gross combination weight (GCW)
Road type:	Any off-highway application on all road types including non-maintained roads
Travel type:	No minimum mileage between couples
Axle limitation:	No axle limitations
Special applications:	All logging, mining and oil field applications fall into this category regardless of anticipated weight, road type or number of axles

Lubrication Instructions

No-Slack® 6000, 7000, 7000CC, NT and H7

1 Inspect top plate (degrease if necessary). Lubricate grease channels in the top plate using a lithium complex lubricant, suitable for use in high pressure applications (all models except Clean Connect™)

WARNING! Do not use an aftermarket lube plate (high density polyethylene) or grease packets on top of the fifth wheel or kingpin bolster plate in lieu of grease without prior approval by Fontaine.



2 Lubricate the top plate surface with a thin layer of grease—leave area around jaw and wedge free of grease (skip this step for the 7000CC Clean Connect™ model).



Note: For illustration purposes, red lubricant is used in these photos to show proper coverage. Your grease may have a different color.



Over-lubrication is costly and causes excessive build-up on fifth wheel components leading to lost revenue.

3 Remove any old grease from the jaw, wedge and the throat area of the fifth wheel, then close the lock and grease the jaw and wedge (all models)

Trip the locking mechanism with a pry bar by pushing the bumper off its seat. Keep hands out of the fifth wheel throat.



Separate the jaw and wedge with a screw driver and press the recommended lubricant between the serrated surfaces. Work the pull-handle back and forth to spread the lube over all surfaces. Also grease the Stationary Jaw and the Throat Area above the Stationary Jaw.

4 Grease mounting brackets (Skip this step for "LUBE FREE" models with bracket liner models)



Grease the mounting brackets. Lift the top plate up with a pry bar to ensure grease gets to the top of the brackets. (Inspect mounting bracket base, and if "LUBE FREE" is cast into the bracket skip this step. These models have bracket liners and do not require lubrication. In this case inspect linings for wear). **In cold weather applications please refer to page 27.**

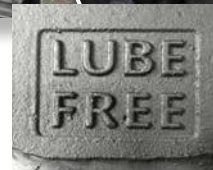

Jaw & Wedge Adjustment

No-Slack® 6000, 7000, 7000CC, NT and H7

1 Insert test kingpin into fifth wheel throat to activate the lock



Insert a dimensionally correct test kingpin tool into the throat of the fifth wheel. Carefully push the kingpin in until the locking mechanism is activated. Keep your hands out of the fifth wheel throat.



3 Verify fifth wheel lock is activated



Verify that the pull handle is in the fully locked position (within 1" of the fifth wheel skirt).

2 Adjust wedge stop rod

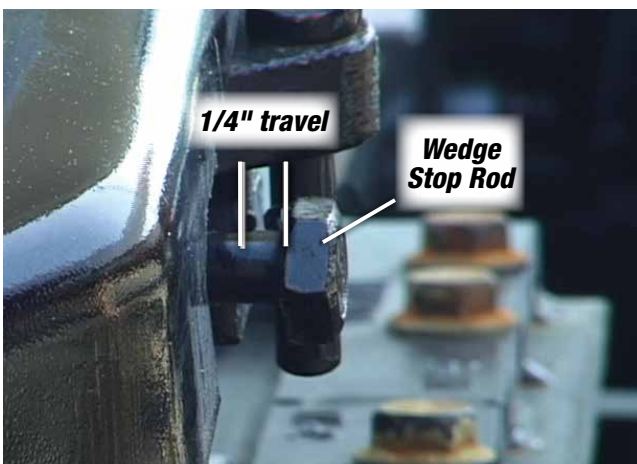

Check the travel of the wedge stop rod by pushing in on it. It should move in 1/4" with hand pressure and then spring back out. To obtain a proper setting, turn the wedge stop rod clockwise to reduce the gap and counter-clockwise to increase it. Adjust until the free travel is 1/4".

Hint:

If necessary, tap the wedge stop rod with a hammer to release a tight wedge.



IMPORTANT: Fontaine Training Videos are a great resource that can save time and improve the efficiency of your business. Subjects cover rebuilding a fifth wheel, coupling and uncoupling, maintenance and more. Check them out at <http://www.fifthwheel.com/fifth-wheel-videos.html> or scan this QR code with your mobile device.

Cold Weather Maintenance

No-Slack® 6000, 7000, 7000CC, NT and H7

Note:



Special precautions should be taken during extreme cold weather to ensure that the fifth wheel locking mechanism operates freely. At low temperatures ice and sludge can build up, and lubricants can become thick and binding. If you are in a region that experiences extreme and/or prolonged freezing temperatures (below 0°F) a thorough cleaning and de-greasing of the fifth wheel should be performed followed by lubrication with a less viscous lubricant. Following is the recommended cold weather procedure. (Refer to LT-072 for lubricating instructions under normal conditions).

WARNING! You should never attempt to couple a fifth wheel that has snow, ice, or debris in the throat area. Improper coupling can occur possibly resulting in serious injury or death.

1 Remove all snow, ice and debris from the fifth wheel especially focusing on the throat area; and remove all hardened lubricants that bind the locking mechanism.



2 Lubricate top plate and locking mechanism.



Fontaine suggests the use of a lithium complex grease when applying lubricant (see LT-072 for lubricating instructions). However, in extreme cold conditions a less viscous lubricant should be used, such as: 90-weight oil, diesel fuel, kerosene, motor oil, etc. (unless prohibited by government regulations). This will help ensure proper movement and lubrication of the locking mechanism in extreme cold weather. This less viscous lubricant can be distributed using a spray bottle. Be sure to spray the top surface of the fifth wheel and all moving components including the pull handle, throat area (jaw and wedge) and secondary lock. Fontaine recommends that you contact your specific lubricant manufacturer for guidelines on mixing compatibility of any lubricant.

3 After application of fresh lubricant, open and close the lock several times to make sure that it is operating freely.



Close the lock using a pry bar

Move pull-handle back and forth to distribute lube

Close the lock by inserting a pry bar into the throat of the fifth wheel to activate the trigger mechanism. **Keep hands out of the fifth wheel throat.** Move the handle back and forth several times without fully engaging the lock to distribute the fresh lubricant.



Switch to Genuine Fontaine No-Slack®

We make it **EASY**

Select complete assemblies now
up to 50% off!

STANDARD DUTY



5 NEW YEAR WARRANTY

NO-SLACK®

Stamped steel top plate
6000 Series

Standard-duty on-highway
50,000 lbs vertical load
150,000 lbs drawbar pull

MODERATE DUTY



5 NEW YEAR WARRANTY

NO-SLACK®

Cast steel top plate
7000 Series

Moderate-duty maintained asphalt or gravel
55,000 lbs vertical load
150,000 lbs drawbar pull

HEAVY-DUTY



5 NEW YEAR WARRANTY

NO-SLACK®

Cast steel top plate
H7 Series Heavy Duty

Heavy-duty on/off-highway
62,500 lbs vertical load
150,000 lbs drawbar pull

- Each complete assembly includes top plate and mount.
- **Easily bolts to existing outboard angles for a quick, easy conversion.**
- Now you can run with the best for less. We make it **EASY** at the Fontaine Conversion Center.

www.fifthwheel.com/convert

Mounting Bolt Kit **KIT-BOLT-24**

NEW!

Kit has hardware you need to install any Fontaine 12", 16" or 24" sliding mount to the truck chassis. Same kit can be used for fixed mounts (includes 20 Grade 8 bolts with matching locknuts and 40 hardened washers).



Quantity 20

Helpful On-Line Information

Scan these links, or go to fifthwheel.com

How to select fifth wheel



Choose "Support" menu, then "Spec my Truck"

Operation/Maintenance Videos



Choose "Videos" menu.

Troubleshooting Support



Choose "Support" menu Then "Troubleshooting"

Helpful Documents



Choose "Literature" menu.

