

FONTAINE

Parts Guide for Fontaine® No-Slack® 6000, 7000, 7000CC and NT Series Fifth Wheels

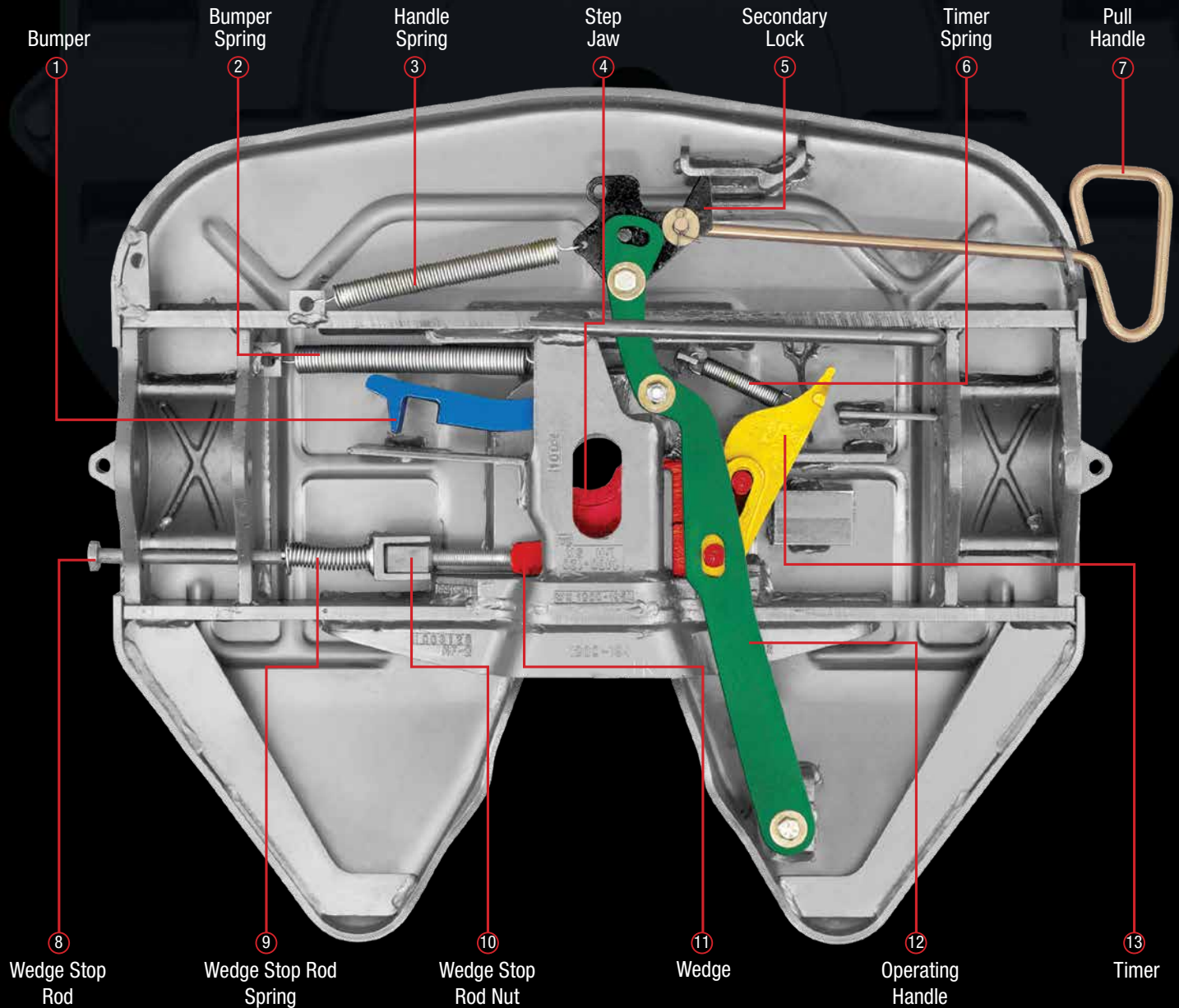

Left hand SLTPL6000 model shown

Description	Part Number	Fits	Weight (lbs)	Contains
Repair Kit	KIT-RPR-6000*	6000,7000,7000CC,NT,H7	8	②③④⑥⑩
Rebuild Kit (Driver Side)	KIT-RX-67NTL	6000,7000,7000CC,NT	23	All
Rebuild Kit (Passenger)	KIT-RX-67NTR	6000,7000,7000CC,NT	23	All
Pull Handle	KIT-PUL-6000*	6000,7000,7000CC,NT	2.2	⑦
Pull Handle H7	KIT-PUL-H7	H7	2.2	⑦
Operating Handle	KIT-OPR-6000	6000,7000,7000CC,NT	5.2	⑫
Operating Handle H7	KIT-OPR-H7	H7	5.2	⑫
Timer Kit (Driver Side)	KIT-TMR-6000L	6000,7000,7000CC,NT,H7	3.4	⑬⑥
Adjustment Rod Kit	KIT-ROD-1108	6000,7000,7000CC,NT,H7	1.5	⑧⑨⑩
Bumper Kit (Driver Side)	KIT-BPR-6000L	6000,7000,7000CC,NT,H7	3.7	①②
Spring Kit	KIT-SPRING	6000,7000,7000CC,NT,H7	1.1	②③⑥
Replacement top plate	SLTPL7000	6000,7000	246	Complete
Replacement top plate	SLTPL6000	6000	205	Complete
Replacement top plate	SLTPLUNT	NT,LT,3000,4000	220	Complete

Part numbers that start with "KIT" include installation hardware.

* Part can be a L (left) or R (right).



No-Slack® NT/6000/7000/7000CC

No-Slack® Top Plate Kits

Repair

Repair kit (KIT-RPR-6000L or R)

Item	Description	Qty.
⑥	Bumper spring	1
⑦	Handle spring	1
⑰	Timer spring	1
⑳	Step jaw	1
㉑	Wedge	1
⑩	Bushing, 7/16"	1
⑮	Bushing, 5/16"	1
⑲	Bushing, 1 1/4"	1
⑫	Hex lock nut, 1/2" - 13	3

Spring kit (KIT-SPRING)*

⑥	Bumper spring	1
⑦	Handle spring	1
⑰	Timer spring	1

Wedge-stop rod kit (KIT-ROD-1108)*

①	Wedge-stop rod nut	1
②	Flat washer, 5/8" I.D.	2
③	Wedge-stop rod spring	1
④	Wedge-stop rod	1
⑤	Cotter pin, 3/16" x 1"	1

Secondary lock kit (KIT-LAT-6000L)

⑦	Handle spring	1
⑧	Hex head bolt, 1/2" - 13	1
⑨	Flat washer, 1/2" I.D.	2
⑩	Bushing, 7/16"	1
⑪	Secondary lock	1
⑫	Hex lock nut, 1/2" - 13	1
⑤	Cotter pin, 3/16" x 1"	1

Pull handle kit (KIT-PUL-6000L or R)

⑬	Pull handle	1
⑭	Flat washer, 1/2" I.D.	1
⑤	Cotter pin, 3/16" x 1"	1

Bumper kit (KIT-BPR-6000L)

⑫	Hex lock nut, 1/2" - 13	1
⑭	Flat washer, 1/2" I.D.	2
⑮	Bushing	1
⑧	Hex head bolt, 1/2" - 13	1
⑯	Bumper	1
⑥	Bumper spring	1

Timer kit (KIT-TMR-6000L)

⑰	Timer spring	1
⑱	Timer	1
⑫	Hex lock nut, 1/2" - 13	1
⑤	Hair pin cotter	1

Operating handle kit (KIT-OPR-6000)*

⑩	Bushing, 7/16"	1
⑮	Bushing, 5/16"	1
⑲	Bushing, 1 1/4"	1
⑫	Hex lock nut, 1/2" - 13	3
⑨	Flat washer, 1/2" I.D.	2
⑧	Hex head bolt, 1/2" - 13	1
⑳	Operating handle	1
⑤	Hair pin cotter	1

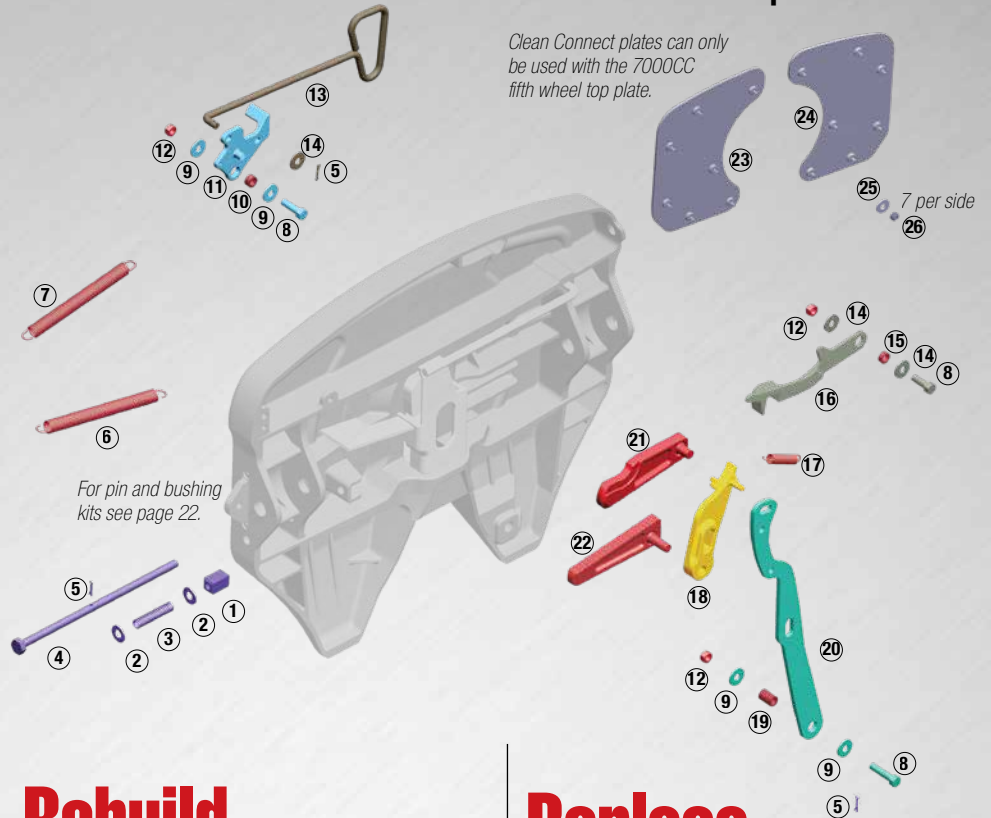

Rebuild

Part number: KIT-RX-67NTL

Major rebuild kit for left side (driver) handle release NT/6000/7000/7000CC.

Kit does not include bracket pins, bushings or Clean Connect plate kits.



Part number: KIT-RX-67NTR

Major rebuild kit for right side (passenger) handle release NT/6000/7000/7000CC.

Kit does not include bracket pins, bushings or Clean Connect plate kits.



7000CC Options

Item	Description	Qty.
Clean Connect plate kits (7000CC)		
(CCR-PLATES-R)		
⑳	Right CC plate	1
㉑	Flat washer	7
㉒	Hex lock nut	7
(CCR-PLATES-L)		
㉑	Left CC plate	1
㉑	Flat washer	7
㉒	Hex lock nut	7

Replace

Replace or upgrade your fifth wheel top plate.



SLTPL7000 (Driver side)
AATPL7000 (Air Actuated)

No-Slack® 7000 Cast

Rated for moderate duty on both on-highway and off-highway applications



SLTPL6000 (Driver side)
AATPL6000 (Air Actuated)

No-Slack® 6000 Stamped Steel

Rated for standard to moderate duty on-highway



SLTPL7000CC (Driver side)
AATPL7000CC (Air Actuated)

No-Slack® 7000CC Clean Connect Cast

Rated for moderate duty for on-highway applications



SLTPLUNT (Driver side)

No-Slack® NT Stamped Steel

Rated for standard to moderate duty on-highway

SLTPLUNT replaces NT and 3000 models only.

*Works for driver and passenger side models.

No-Slack® NT/6000/7000/7000CC

No-Slack® Top Plate Kits

Repair

Repair kit (Driver side: **KIT-RPR-6000L**, Passenger side: **KIT-RPR-6000R**)



Item	Qty.
Bumper spring	1
Handle spring	1
Timer spring	1
Step jaw	1
Wedge	1
Bushing, 7/16"	1
Bushing, 5/16"	1
Bushing, 1 1/4"	1
Hex lock nut, 1/2" - 13	3

Secondary lock kit (**KIT-LAT-6000L**)



Item	Qty.
Handle spring	1
Hex head bolt, 1/2" - 13	1
Flat washer, 1/2" I.D.	2
Bushing, 7/16"	1
Secondary lock	1
Hex lock nut, 1/2" - 13	1
Cotter pin, 3/16" x 1"	1

Pull handle kit (Driver side: **KIT-PUL-6000L**, Passenger side: **KIT-RPR-6000R**)



Item	Qty.
Pull handle	1
Flat washer, 1/2" I.D.	1
Cotter pin, 3/16" x 1"	1

For H7 pull handle
order KIT-PUL-H7

Timer kit (**KIT-TMR-6000L**)



Item	Qty.
Timer spring	1
Timer	1
Hex lock nut, 1/2" - 13	1
Hair pin cotter	1

Air actuated kit

Part number:
KIT-AA-6000L

Description

Description	Quantity
① Air Cylinder	1
② Clevis Pin Long	1
③ Clevis Pin Short	1
④ Springs	2
⑤ Flat Washer 1/2"	2
⑥ Cotter Pin 5/32"	2
⑦ Exhaust Valve	1
⑧ Quick Disconnect Valve	1

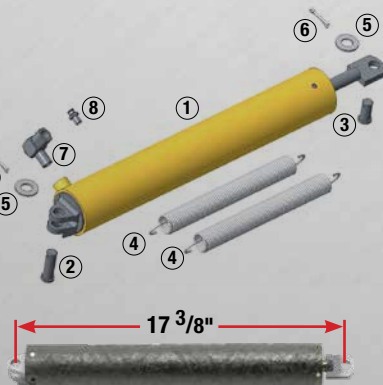

17 3/8"

1/2" diameter holes

Wedge-stop rod kit (**KIT-ROD-1108**)



Item	Qty.
Wedge-stop rod nut	1
Flat washer, 5/8" I.D.	2
Wedge-stop rod spring	1
Wedge-stop rod	1
Cotter pin, 3/16" x 1"	1

Spring kit (**KIT-SPRING**)



Item	Qty.
Bumper spring	1
Handle spring	1
Timer spring	1

Bumper kit (**KIT-BPR-6000L**)



Item	Qty.
Hex lock nut, 1/2" - 13	1
Flat washer, 1/2" I.D.	2
Bushing	1
Hex head bolt, 1/2" - 13	1
Bumper	1
Bumper spring	1

Operating handle kit (**KIT-OPR-6000**)



Item	Qty.
Bushing, 7/16"	1
Bushing, 5/16"	1
Bushing, 1 1/4"	1
Hex lock nut, 1/2" - 13	3
Flat washer, 1/2" I.D.	2
Hex head bolt, 1/2" - 13	1
Operating handle	1
Hair pin cotter	1

For H7 operating handle
order KIT-OPR-H7

Part number:

KITKPT



*Test kingpin is an excellent tool
for jaw and wedge adjustment.*

Pin and Bushing Kits

Bracket Pin and Bushing Kits

Bracket pin kit (KIT-PIN-LLB)



Item	Qty.
2-piece bushing	2 Pairs
Bracket pin	2
Bracket retainer pin	2
Cotter pin	2
Bracket liner	2

Bracket pin kit (KIT-PIN-191)



Item	Qty.
1-piece bushing	2
Bracket pin	2
Bracket retainer pin	2
Cotter pin	2

Bracket pin kit (KIT-PIN-UNT)



Item	Qty.
1-piece bushing	2
Bracket pin	2
Bracket retainer pin	2
Cotter pin	2
Bracket Liner	2

Bracket pin kit (KIT-PIN-3000)



Item	Qty.
Bracket liners	2
1-piece bushing	2
Bracket pin	2
Bracket retainer pin	2
Cotter pin	2

Bushing Kits

Bushing kit (BSH-LLB)



Item	Qty.
2-piece bushing	2 Pairs
Bracket liner	2

Bushing kit (BSH-150)



Item	Qty.
1-piece bushing	2

Bracket Pin and Bushing Kit Guide

Top Plate Mount	Top Plate	Bracket Pin Kit	Bushing Kit
Sliding Brackets			
ATB	6000, 7000, 7000CC	KIT-PIN-LLB	BSH-LLB
AWB	7000, H5092, H7	KIT-PIN-191	BSH-150
AWB Blocked BLAWB	7000, H5092, H7	KIT-PIN-191	BSH-150
AWX	H5092, H7	-	BSH-150
LWB	6000, 7000, 7000CC	KIT-PIN-LLB	BSH-LLB
LWO	NT, 3000	KIT-PIN-UNT*	-
MTB	6000, 7000, 7000CC	KIT-PIN-LLB	BSH-LLB
MWS	H5092, H7	KIT-PIN-191	BSH-150
NWB	6000	KIT-PIN-LLB	BSH-LLB
XPSA	X5092	-	BSH-150
ASB	NT, 3000	KIT-PIN-3000	-

Top Plate Mount	Top Plate	Bracket Pin Kit	Bushing Kit
Fixed Mount/Plate Mount			
APB	NT, 3000	KIT-PIN-UNT*	-
BSL	6000, 7000, 7000CC	KIT-PIN-LLB	BSH-LLB
BSM	6000, 7000, 7000CC	KIT-PIN-LLB	BSH-LLB
FMA	6000, 7000, 7000CC	KIT-PIN-191	BSH-150
FMA D3	6000, 7000, 7000CC	KIT-PIN-191	BSH-150
PMA	6000, 7000, 7000CC	KIT-PIN-LLB	BSH-LLB
PML	6000, 7000, 7000CC	KIT-PIN-LLB	BSH-LLB
PSA	H5092, H7	KIT-PIN-191	BSH-150
PS5	H5092, H7	KIT-PIN-191	BSH-150
PS5 Blocked (BLPS5)	H5092, H7	KIT-PIN-191	BSH-150
SMB	NT, 3000	KIT-PIN-UNT*	-
XPSA	X5092	-	BSH-150

*If 3000 Series top plate on the bracket or slide, use KIT-PIN-3000.



www.fifthwheel.com • 800-874-9780 • Email: parts@fifthwheel.com

